

MaxQ 3000 Open-Air Platform Shaker

Operating Manual and Parts List 057-285-00 Rev. 0



Models Covered In This Manual	
Model numbers	Voltage
SHKA3000 (4312)	120V
SHKE3000 (4318)	240V
SHKA3000-1CE (4313)	120V
SHKE3000-1CE (4319)	240V

MANUAL NUMBER 057-285-00 (7004312)

0	--	3/19/10	Transfer to Marietta (was 057-285-00 3/6/09)	ccs
REV	ECR/ECN	DATE	DESCRIPTION	By



Important Read this instruction manual. Failure to read, understand and follow the instructions in this manual may result in damage to the unit, injury to operating personnel, and poor equipment performance. ▲

Caution All internal adjustments and maintenance must be performed by qualified service personnel. ▲

Material in this manual is for information purposes only. The contents and the product it describes are subject to change without notice. Thermo Fisher Scientific makes no representations or warranties with respect to this manual. In no event shall Thermo be held liable for any damages, direct or incidental, arising out of or related to the use of this manual.

©2010 Thermo Fisher Scientific. All rights reserved.



Important operating and/or maintenance instructions. Read the accompanying text carefully.



Potential electrical hazards. Only qualified persons should perform procedures associated with this symbol.



Equipment being maintained or serviced must be turned off and locked off to prevent possible injury.



Hot surface(s) present which may cause burns to unprotected skin, or to materials which may be damaged by elevated temperatures.



Marking of electrical and electronic equipment, which applies to electrical and electronic equipment falling under the Directive 2002/96/EC (WEEE) and the equipment that has been put on the market after 13 August 2005.



This product is required to comply with the European Union's Waste Electrical & Electronic Equipment (WEEE) Directive 2002/96/EC. It is marked with the WEEE symbol. Thermo Fisher Scientific has contracted with one or more recycling/disposal companies in each EU Member State European Country, and this product should be disposed of or recycled through them. Further information on Thermo's compliance with this directive, the recyclers in your country and information on Thermo products will be available at www.thermofisher.com.

- ✓ Always use the proper protective equipment (clothing, gloves, goggles, etc.)
- ✓ Always dissipate extreme cold or heat and wear protective clothing.
- ✓ Always follow good hygiene practices.
- ✓ Each individual is responsible for his or her own safety.

Do You Need Information or Assistance on Thermo Scientific Products?

If you do, please contact us 8:00 a.m. to 6:00 p.m. (Eastern Time) at:

1-740-373-4763

1-800-438-4851

1-877-213-8051

<http://www.thermofisher.com>

service.led.marietta@thermofisher.com

Direct

Toll Free, U.S. and Canada

FAX

Internet Worldwide Web Home Page

Service E-Mail Address

Our **Sales Support** staff can provide information on pricing and give you quotations. We can take your order and provide delivery information on major equipment items or make arrangements to have your local sales representative contact you. Our products are listed on the Internet and we can be contacted through our Internet home page.

Our **Service Support** staff can supply technical information about proper setup, operation or troubleshooting of your equipment. We can fill your needs for spare or replacement parts or provide you with on-site service. We can also provide you with a quotation on our Extended Warranty for your Thermo Scientific products.

Whatever Thermo Scientific products you need or use, we will be happy to discuss your applications. If you are experiencing technical problems, working together, we will help you locate the problem and, chances are, correct it yourself...over the telephone without a service call.

When more extensive service is necessary, we will assist you with direct factory trained technicians or a qualified service organization for on-the-spot repair. If your service need is covered by the warranty, we will arrange for the unit to be repaired at our expense and to your satisfaction.

Regardless of your needs, our professional telephone technicians are available to assist you Monday through Friday from 8:00 a.m. to 6:00 p.m. Eastern Time. Please contact us by telephone or fax. If you wish to write, our mailing address is:

Thermo Fisher Scientific
401 Millcreek Road, Box 649
Marietta, OH 45750

International customers, please contact your local Thermo Scientific distributor.

Table of Contents

Section 1	Safety Information	1-1
Section 2	General Specifications	2-1
	Environmental Conditions	2-3
	A-Class Control Panel Features	2-4
	E-Class Control Panel Features	2-5
Section 3	Unpacking and Installation	3-1
	Unpacking	3-1
	Location	3-1
	Electrical Requirements	3-2
	Adjusting Shaker Feet	3-2
	Platform Installation	3-3
	Flask Clamp Installation	3-3
	Test Tube Rack Installation	3-4
Section 4	Operation	4-1
	Turning the Shaker On	4-2
	Setting Shaking Speed	4-2
	Calibrating Shaking Speed	4-2
	RS232 Interface Port	4-3
	Setting Timer for Continuous Shaking	4-3
	Setting Timer for Timed Shaking	4-3
	Hyperterminal Configuration	4-4
Section 5	Maintenance	5-1
Section 6	Troubleshooting	6-1
Section 7	Replacement Parts	7-1
	Ordering Procedures	7-2

Section 1 Safety Information

Your Thermo Scientific MaxQ 3000 Shaker has been designed with function, reliability, and safety in mind. It is your responsibility to install it in conformance with local electrical codes. For safe operation, pay attention to the alert signals (Warnings, Cautions, Notes) throughout the manual.

This manual contains important operating and safety information. The user must carefully read and understand the contents of this manual prior to the use of this equipment.

Warnings

To avoid electrical shock, always:

1. Use a properly grounded electrical outlet of correct voltage and current handling capacity.
2. Disconnect from the power supply prior to maintenance and servicing.

To avoid personal injury:

1. Do not use in the presence of flammable or combustible materials — fire or explosion may result. This device contains components which may ignite such materials. Not rated for use in hazardous atmospheres.
2. Use appropriate hand and eye protection when handling hazardous chemicals.
3. Refer servicing to qualified personnel.
4. Do not modify construction and/or assembly of equipment.
5. Do not remove tags, labels, decals, or other information from the unit.
6. Stand clear of equipment when it is operating.
7. If shaking action will result in the evolution of gases or fumes, perform the operation in a well-ventilated laboratory hood.

8. Use equipment only for its intended purpose. Use only the accessories and attachments that are shipped with the equipment, or are specified for it. Substituting other attachments or accessories can produce hazards or make the unit inoperative.
9. Perform regular maintenance service as specified in this manual and keep unit in good repair. Do not operate with known defects.
10. User is to determine optimum load/speed combinations to ensure that shaker operates safely with a balanced load. Normal operation can include the requirements of the type of studies to be performed, i.e. aeration, solubility, mixing, etc. The vessels should be securely clamped before turning on shaker and contain a stopper whenever possible to prevent hazardous substances from being thrown out during shaking action. Shaking action should be set to begin at a slow speed and gradually increased to desired speed. Additional embracing is required for 4-50 lbs at 450-500 rpm.

Note The figured 40-50 lbs at 450-500 rpm is based on the SHKE3000 performance and is presented per UL requirement. ▲

Note If operating in the shade region, unit stabilizer kit #190-640-00 must be used in order to maintain safe operation. Kit may be ordered directly from the factory at no charge. ▲

	10 lbs	20 lbs	30 lbs	40 lbs	50 lbs
100 rpm	No	No	No	No	No
200 rpm	No	No	No	No	No
300 rpm	No	No	No	No	No
325 rpm	No	No	No	No	No
350 rpm	No	No	No	No	No
400 rpm	No	No	No	No	No
450 rpm	No	No	No	Yes	Yes
475 rpm	No	No	No	Yes	Yes
500 rpm	No	No	No	Yes	Yes

Section 2 General Specifications

Model No.	SHKA3000	SHKA3000-1CE	SHKE3000	SHKE3000-1CE
Exterior Unit Dimensions in. (cm)				
Width inch (cm)	29.4 (74.7)	29.4 (74.7)	29.4 (74.7)	29.4 (74.7)
Height inch (cm)	9.7 (24.6)	9.7 (24.6)	9.7 (24.6)	9.7 (24.6)
Length inch (cm)	25.8 (65.5)	25.8 (65.5)	25.8 (65.5)	25.8 (65.5)
Weight lbs (kg)	171 (77.6)	171 (77.6)	171 (77.6)	171 (77.6)
Electrical				
Volts (AC)	120	220-240	120	220-240
Amps	1.0	1.6	1.5	0.8
Watts	100	190	185	185
Freq.	50/60	50/60	50/60	50/60
Speed	40 to 400 rpm, ± 10 rpm	40 to 400 rpm, ± 10 rpm	15 to 500 rpm, ± 1 rpm	15 to 500 rpm, ± 1 rpm
Timer	Continuous or timed from 1-60 mins.	Continuous or timed from 1-60 mins.	Continuous or timed 0.1-999 hours or 0.1-999 min.	Continuous or timed 0.1-999 hours or 0.1-999 min.
Recorder Output	None	None	None	None
RS232 Interface*	None	None	Monitor speed and time with a computer	Monitor speed and time with a computer
Display	Analog tachometer displays speed in rpm	Analog tachometer displays speed in rpm	2 individual LED displays indicate time and speed simultaneously. 3 characters height 1/2 inches (1.27 cm)	2 individual LED displays indicate time and speed simultaneously. 3 characters height 1/2 inches (1.27 cm)
Soft Start Feature	None	None	Software algorithms prevent sudden start/stops	Software algorithms prevent sudden start/stops
Mutable Alarms	None	None	Audible portion of the alarm can be silenced for a period of 1hr. without deactivating the actual alarm condition by depressing any key	Audible portion of the alarm can be silenced for a period of 1hr. without deactivating the actual alarm condition by depressing any key

** Interface cables not to exceed 9.8' (3m) in length*

Section 2
General Specifications

Model No.	SHKA3000	SHKA3000-1CE	SHKE3000	SHKE3000-1CE
Motor	Permanent Magnet DC	Permanent Magnet DC	Solid State Brushless DC	Solid State Brushless DC
Alarms				
Speed	None	None	Audible with flashing LED indicates when speed deviates more than 10% of set point	Audible with flashing LED indicates when speed deviates more than 10% of set point
Speed Shut Off	None	None	When speed deviates 10% of set point, unit will shut down immediately	When speed deviates 10% of set point, unit will shut down immediately
Timer	None	None	Beeps twice when time has expired. Shaking motion stops	Beeps twice when time has expired. Shaking motion stops
Unbalanced Load	None	None	If the unit is running in an unbalanced condition, an alarm will sound and the shaker will stop until the end user corrects the condition. The speed display will flash "bAL" on speed panel LED.	If the unit is running in an unbalanced condition, an alarm will sound and the shaker will stop until the end user corrects the condition. The speed display will flash "bAL" on speed panel LED.

Optional Platform Dimensions in. (cm)	
Catalog Number	L x W
30115	Universal 30" x 18" (76.2 x 45.7 cm)
30120	Universal 36" x 24" (91.4 x 60.9 cm)
30124 Dual Tier	Universal 30"x 18" (76.2 x 45.7 cm)

The Thermo Scientific MaxQ 3000 Series bench top, orbital, open-air shakers are available in one of two control configurations:

- SHKA3000 and SHKA3000-1CE incorporate a mechanical timer for the control of time and speed, adjustable with rotary dials. Analog tachometer displays speed in RPM, verifying accuracy of speed setting.
- SHKE3000 and SHKE3000-1CE control time and speed by a microprocessor controller, adjustable with arrow keys on keypad in one rpm increments. Flashing display indicates power interruption. Pressing any key will clear display. Non-volatile memory maintains speed and time set points in the event of a power interruption. Speed and time set points are automatically reactivated after power is restored. User adjustable speed calibration allows end user to calibrate the shaking speed to a known value.

In addition, both versions offer:

- 1 inch (2.54 cm) triple eccentric orbital drive
- 6 permanently lubricated ball bearings
- 50 lb (22.7 kg) platform load capacity at safe speeds less than 400 rpm for SHKA3000/SHKA3000-1CE and less than 500 rpm for SHKE3000/SHKE3000-1CE
- UL, cUL and CE certification

Environmental Conditions

Pollution Degree**2
Installation Category**II
Altitude 3000 meters MSL (Mean Sea Level)
Relative Humidity 20% to 80% maximum, non-condensing
Electrical Supply120 VAC or 240 VAC
Voltage Tolerance+10% of normal rated line
Temperature0°C to 40°C
Product Usage This product is intended for use indoors only

**Refer to IEC 664-1

Caution It's not recommended to operate shaker in a CO2 enriched atmosphere. Formation of carbonic acid could cause electrical failures. ▲

A-Class Control Panel Features

1. Power Switch: Turns power on and off to shaker
2. Speed Control: Sets platform rotation speed
3. Speed Tachometer: Analog display of platform rotation speed
4. Time(r): Allows user to choose either continuous or timed operation

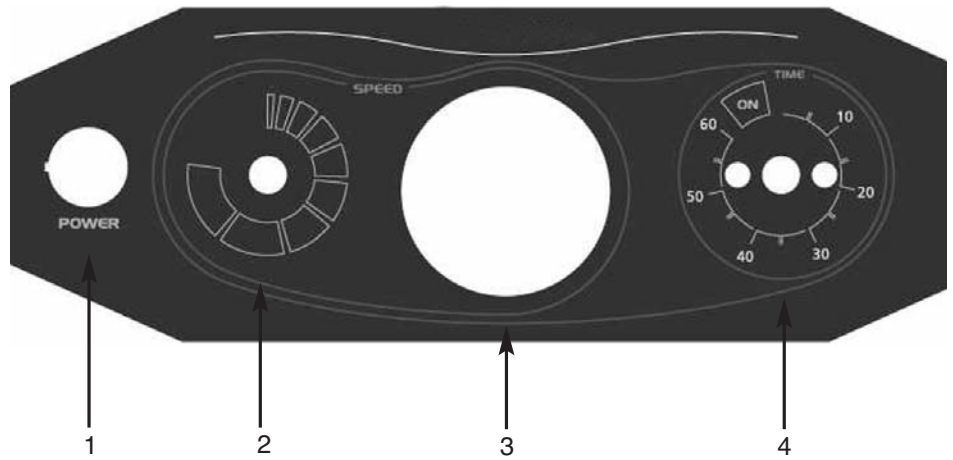

E-Class Control Panel Features

1. Power Switch: Turns power on and off to shaker
2. Speed Display: 3 digit LED indicates actual or set point speed
3. Up Arrow Key: Increases platform rotation speed
4. Down Arrow Switch: Decreases platform rotation speed
5. Speed Light: Red light Illuminates when a locked rotor or over-speed condition exists
6. RPM Light: Illuminates to indicate actual speed
7. Set RPM Light: Illuminates when speed is being set
8. Stop Switch: Stops platform rotation
9. Start Switch: Starts platform rotation
10. Time(r) Display: 3 digit LED indicates time remaining or elapsed time
11. Up Arrow Key: Increases shaking time
12. Down Arrow Key: Decreases shaking time
13. Elapsed Timer Light: Indicates accumulated time
14. Hours: Timer indicates hours
15. Minutes: Timer indicates minutes
16. Set Time: Illuminates when time is being set
17. Timer/Elapsed: Allows the user to choose elapsed time operation, Elapsed, or timed operation, Timer
18. Hours/Minutes Key: Allows user to choose timing operation in either hours or minutes

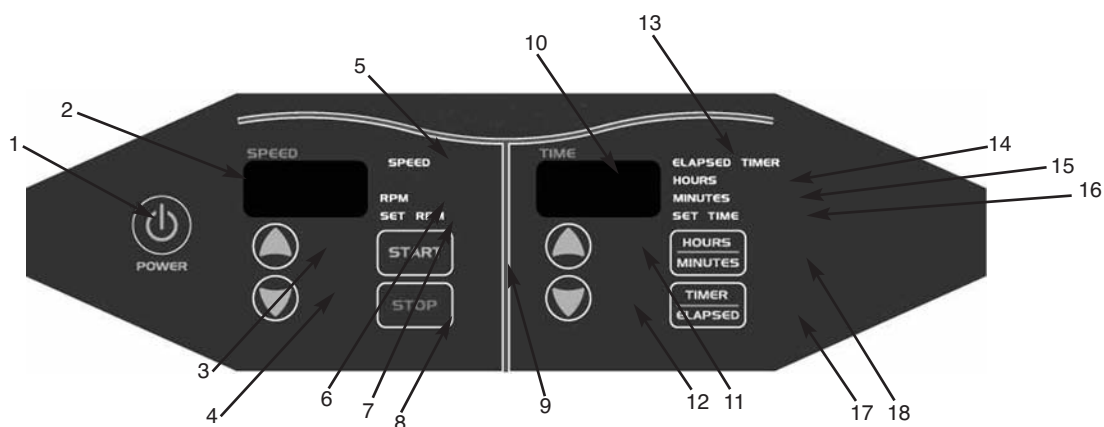

Section 3 Unpacking and Installation

The shipping carton should be inspected upon delivery. When received, carefully examine for any shipping damage before unpacking. If damage is discovered, the delivering carrier should specify and sign for the damage on your copy of the delivery receipt.

Open the carton carefully making certain that all parts are accounted for before packaging materials are discarded. After unpacking, if damage is found, promptly report it to the carrier and request a damage inspection properly.

Important Failure to request an inspection of damage within a few days after receipt of shipment absolves the carrier from any liability for damage. Call for a damage inspection promptly. ▲

Unpacking

Use the packing list below when unpacking to verify that the complete unit has been received. Do not discard packing materials until all is accounted for.

The following items are included in the shipment:

Operating Manual- 057-285-00

Product Registration Card- 36093

Allen Wrench - 935-032-00

If any items are missing, contact Thermo.

Location

Put the shaker on a level table or bench capable of supporting the weight of the shaker with any accessories while in operation. Place shaker near an electrical outlet that matches the unit nameplate requirements.

Allow 12” clearance around the unit for free air convection, accessory attachments and user convenience.

Electrical Requirements

SHKA3000, SHKE3000, and SHKE3000CO2 require a 120VAC, 50/60 Hz power source. They are supplied with a 3-wire line cord and should be plugged into an outlet designed for 3-prong plugs. If an extension cord is used, it also should be the 3-wire grounded type. For an outlet designed to accept 2-prong plugs (ungrounded), it is required that a qualified electrician replace the outlet with a new, grounded type.

SHKA3000-1CE, SHKE3000-1CE, and SHKE3000CO2-1CE require a 240VAC, 50/60 Hz power source. Power cords are supplied.

If a plug must be installed, use only the 3-prong grounded type, rated for the unit load requirements and matching the power outlet. Make sure the green ground wire is secured to the plug ground terminal.

Warning Do not operate shaker with a damaged electrical cord. ▲

To eliminate hazard of electrical shock, make sure floor around shaker is dry. In the event of accidental spilling or splashing of liquids, clean up and/or neutralize the spilled liquids before continuing.

Disconnect the shaker from the power source when not in use.

Adjusting Shaker Feet

In order for this shaker to function safely, the feet must be adjusted before use so that all four feet are in good contact with the floor, and reasonably level.

It is very important that this unit have the feet adjusted in the position in which it will be used, and if moved, must be re-adjusted in the new location before use. This will help prevent the unit from 'walking' at higher speeds and loads. To accomplish this, proceed as follows:

1. Using a level, set all four feet to a height so that the unit is sitting level.
2. Tighten the jam nuts on the two rear feet to the bottom of the cabinet. This will lock the rear feet.

Warning A shaker with poorly adjusted feet will be unstable and possibly dangerous. ▲

3. Check the unit for rocking. Run the unit slowly. If it rocks, one of the front feet is not in full contact with the floor. Using a 3/4" (1.9 cm) open end wrench, adjust the non-contacting front foot downward so that it makes good contact with the floor. This can be easily accomplished with the unit slowly running, since the foot being adjusted is intermittently off the floor.

Adjusting Shaker Feet (continued)

4. Add load and speed. If unit continues to rock, continue to adjust the non-contacting foot downward until it makes good contact with the floor. At this point, friction with the floor will make the foot hard to turn and the unit will be standing with equal load on all four feet.
5. After the adjusting process is complete, tighten the remaining jam nuts on the front feet against the cabinet.

Flask Clamp Installation

Each flask clamp contains a support spring located at the narrow top of the clamp.

Depending on the size of the clamp, the clamp base may contain one or several screws necessary to secure the clamp to the platform. All screws provided with the clamp must be properly attached to the platform.

1. Carefully place the desired vessel in the clamp by first pulling the clamp spring far enough apart to enable the flask base to be positioned inside the clamp. Gently slide the flask into its proper position, securing it to the wider bottom of the clamp. The spring will hold the neck of the flask securely in place and provide security during shaking.
2. Make sure all vessels are securely clamped before turning on unit.

Wherever possible, vessels should contain a stopper to prevent hazardous substances being thrown out during the mixing action.

Warning Do not operate the shaker at speeds that will cause the contents of vessels to be thrown out. ▲

Platform Installation

1. Select the appropriate platform for the vessels to be shaken. A wide variety of platforms and accessories are available:
 - Dedicated platforms have the maximum number of flask clamps attached for safe operation.
 - Combination platforms allow the user to shake a wide variety of different sized vessels on the same platform.
2. Carefully position the platform horizontally over the shaker's mounting plate, aligning the 4 mounting holes.
3. Tighten the 4 flat head knobs to secure platform.

Caution Do not operate shaker with an unbalanced load. Load platforms for optimum stability and operation. Do not lift shaker by the platform. ▲

Section 3

Unpacking and Installation

Test Tube Rack Installation

1. Position the test tube rack on the combination platform so that the cutouts on the rack's outside bottom are aligned with corresponding mounting holes on the platform. There are two cutouts on each side of the rack.
2. Secure the rack to the platform with mounting screws provided with the rack.

Section 4 Operation

SHKA3000, SHKA3000-1CE

Please refer to A-Class Control Panel for reference.

Power Switch

1. Depress top portion of power switch to turn on shaker.
2. Depress bottom portion of power switch to turn off shaker.

Speed Control and Display

1. Slowly rotate the knob on the solid-state speed control clockwise to increase speed and counterclockwise to decrease speed. The markings on the outside of the dial are for reference purposes only.
2. The speed control tachometer provides an analog readout of the actual platform rotation speed up to a maximum of 400 rpm.

Time(r)

1. From the 12 o'clock off position, rotate timer knob counterclockwise to the ON position to initiate continuous operation.
2. For timed operation, rotate timer knob clockwise from 1 minute to 60 minutes. The markings on the side of the dial are in 5-minute increments.

Caution It is recommended that shaking action be started at a low speed in order to check that all vessels are secure and that no spilling of contents will occur. ▲

Warning Do not use shaker to mix flammable materials or where the transfer of mechanical energy to glass could cause glass breakage. ▲

Note Shaker will not operate if the timer is in the Off position. ▲

SHKE3000 and SHKE3000-1CE

Please refer to E-Class Control Panel for reference.

Turning the Shaker On

Beginning with the shaker power being turned off,

1. Press POWER switch once (I) to turn on shaker.
2. Press POWER switch a second time (O) to turn off shaker.

Note There will be a 3 second delay from the time power is turned on to the time the shaker is activated. Control panel will illuminate when shaker power is activated. ▲

Setting Shaking Speed

1. Hold down appropriate arrow key in the SPEED module of the control panel, up or down, until desired speed is set to 500 rpm. SET RPM light will illuminate.
2. Press START button to begin shaking. RPM light will illuminate.
3. Press STOP button to end shaking. SET RPM light will illuminate.

Note Speed can be changed without pressing the start or stop buttons. Simply press the appropriate up or down arrow key until desired rpm is reached. ▲

Calibrating Shaking Speed

1. Choose a speed for which calibration is desired by using the shaker's UP or DOWN arrow keys.
2. Measure current shaker speed by using a digital hand-held tachometer.
3. If the tachometer reading matches the shaker display, no calibration is necessary. If the tachometer reading is different from the shaker's display, then calibration is required.
4. To get into the calibration mode, hold down the START key, press and release the STOP key, then release the START key.
5. The decimal point on the SPEED display will flash indicating you are in the calibration mode.
6. Use the UP or DOWN arrow keys to set the shaker speed to match the tachometer's readout.
7. Press STOP key to enter the new speed value.
8. Press START key to exit the calibration mode.

Setting Timer for Timed Shaking

1. Press TIMER/ELAPSED button until TIMER and SET TIME lights are illuminated. The HOURS or MINUTES light will also light up at this point, depending on which option was previously chosen.
2. Press HOURS/MINUTES button for desired timing mode.
3. Hold down appropriate arrow key in the TIME module of the control panel, up or down, until desired timing cycle is set from 0.1 hour up to 999 hours, or from 0.1 minute to 999 minutes, depending on which timing mode is chosen. SET TIME light will illuminate.
4. Press START to begin timed shaking. Countdown will begin from time set. TIMER and MINUTES or HOURS lights will illuminate and timer will count down from time selected. An audible alarm will sound at the end of the timing cycle and platform rotation will cease.

Setting Timer for Continuous Shaking

1. Press TIMER/ELAPSED button until ELAPSED light is illuminated. The HOURS or MINUTES light will also light up at this point depending on which option was previously chosen.
2. Press HOURS/MINUTES button for desired timing mode.
3. TIME display should show 000. Press START to begin timed shaking. Timer will begin to count up and will display accumulated time in display window. Platform rotation will cease and TIME display will flash when ELAPSED time reaches 999 minutes or 999 hours.

RS232 Interface Port

The RS232 interface port is located on the left side rear of the shaker cabinet and requires the use of a laptop or desktop computer running Microsoft Windows 98 or newer operating system.



RS232 Interface Port

Note RS232 Interface Port is for output only. Interface cables must not exceed 9.8' (3m) in length. ▲

Hyperterminal Configuration

1. Power up the host computer and close any running applications.
2. Open the HyperTerminal application by clicking on “Start” \ “Programs” \ “Accessories” \ “Communications” \ “HyperTerminal.”
3. In the “Connection Description” box, enter the name “Max Q Shaker” and choose an icon and click “OK.”
4. In the “Connect To” box, verify that “COM1” is selected under “Connect Using.” Click “OK.”
5. In the “COM1 Properties” box \ “Port Settings” folder select the following options:

Bits per second: 19200

Data bits: 8

Parity: None

Stop bits: 1

Flow control None

After verifying the above settings, click “OK.”
6. In the main dialog box click on “File” \ “Save.”
7. Exit the program by clicking on “File” \ “Exit” \ “Yes”.
8. Verify the program was saved by going to “Start” \ “Programs” \ “Accessories” \ “Communications” \ “HyperTerminal” \ “Max Q Shaker.”
9. This completes the configuration of HyperTerminal.
10. Turn shaker off and connect computer (COM 1) to shaker (COM PORT) with DB-9 serial printer cable.
11. Start HyperTerminal by clicking on “Max Q Shaker.”
12. Power up shaker. Shaker will screen print

Section 5 Maintenance

Wash the exterior of the unit with a soft cloth using a solution of mild soap and water, rinse off with clean water and dry thoroughly.

Suggested with every 3 months of constant use

Any internal adjustments or repairs must be performed by a qualified service representative.

Remove the platform by loosening 4 flat head screws in the platform center. Remove the sheet metal panel under the platform to expose the belt and interior parts. Inspect the drive belt for wear and proper tension. Order a replacement if necessary.

SHKA3000 and SHKA3000-1CE only

1. Take out the 3 large motor mount screws and lift the motor out.
2. Two brushes are located under plastic caps on opposite sides of the lower part of the motor. Unscrew the plastic caps and slide the brushes out. Replace brushes when they are worn down to 3/16" (.48 cm) in length.
3. Belt tension is automatically set by the location of the motor and is not adjustable.
4. To align a pulley, loosen the motor pulley set screw, slide the pulley up or down into alignment then securely tighten the motor pulley set screw.

Note Make no attempt to service or repair a Thermo product under warranty before consulting your Thermo Fisher Scientific dealer. After the warranty period, such consultation is still advised, especially when the repair may be technically sophisticated or difficult. If assistance is needed beyond what the distributor can provide, call Technical Services. No merchandise should be returned directly to Thermo without prior approval from Thermo. ▲

Warning Disconnect plug from electrical outlet before attempting any maintenance or repair of this unit. ▲

Note The shaking mechanism is equipped with sealed ball bearings which do not require further lubrication or adjustment. ▲

Section 6 Troubleshooting

Problem	Possible Causes	Solutions
Shaker doesn't operate	Check if power cord is plugged in	Plug in
	Check if power supply matches requirements on data label	Locate the power supply that matches unit requirements
	E-Class, Check fuse	Replace fuse
	E-Class, check for flashing lights on control panel	Press any button on control panel
	E-Class, check if elapsed timer is flashing	Reset timer
	A-Class, check if timer is in "off" position	Set timer for continuous or timed operation
	A-Class, check if power switch is functioning	Replace if defective
Platform doesn't rotate or has erratic speed	Check for power to motor	Replace motor if defective
	Check drive belt	Replace if worn, broken or slipped off pulley
	A-Class, check for power to speed control	Replace if defective

Section 7 Replacement Parts

Part Number	Description
150-317-00	Drive Belt
227-598-00	Speed Control, SHKA3000
229-419-00	Speed Control, SHKA3000-1CE
228-612-00	Tachometer PCB SHKA3000, SHKA3000-1CE
660-111-00	Tachometer SHKA3000, SHKA3000-1CE
270-135-00	Timer, SHKA3000, SHKA3000-1CE
330-125-00	Circuit Breaker, 3 Amp
MT1411X1	DC Motor Assembly SHKA3000, SHKA3000-1CE
370-387-00	Brushless DC Motor SHKE3000, SHKE3000-1CE
440-396-00	Power switch, Round SHKA3000, SHKA3000-1CE
470-262-00	Line Cord, SHKA3000, SHKE3000
470-305-00	Line Cord, CE, SHKA3000-1CE, SHKE3000-1CE
CRX108	Line Cord, UK, SHKA3000-1CE, SHKE3000-1CE
CRX115	Line Cord, China, SHKA3000-1CE, SHKE3000-1CE
560-275-00	Knob, Speed Control SHKA3000, SHKA3000-1CE
790-430-00	Mounting Feet
803-603-00	Bearing Plate
019-392-00	Shaker Mechanism
019-534-00	Power/Motor/Drive PCB SHKE3000, SHKE3000-1CE
019-535-00	Display/Time/Speed PCB, SHKE3000, SHKE3000-1CE
229-309-00	Display/Time/Speed PCB, SHKE3000, SHKE3000-1CE

Ordering Procedures

Please refer to the Specification Plate for the complete model number, serial number, and series number when requesting service, replacement parts or in any correspondence concerning this unit.

All parts listed herein may be ordered from the Thermo Fisher Scientific dealer from whom you purchased this unit, or can be obtained promptly from the factory. When service or replacement parts are needed, check first with your dealer. If the dealer cannot process your request, then contact our Technical Services Department.

Prior to returning any materials, please contact our Technical Services Department for a “Return Materials Authorization” number (RMA). Material returned without an RMA number will be refused.

Thermo Scientific
401 Millcreek Road
Marietta, Ohio 45750
United States

www.thermofisher.com

ThermoFisher
S C I E N T I F I C