



WaterPro®

Water Purification Systems



Protecting your
laboratory environment
LABCONCO®



How To Use This Catalog

This catalog contains complete information on the full line of Labconco Water Purification Systems. The catalog begins with an overview of the various water purification technologies available. Next, the WaterPro Water Purification Systems information is organized by System category.

Within these sections you will find general introductory information about each water purification system followed by features and benefits, a flow chart that describes the built-in purification technologies, specifications and ordering information, performance data, technical specifications, replacement supplies and dimensional data. Please refer to the Table of Contents below for the specific page number for each water purification system.

Before turning to a section, refer to the Selection Guide on page 5 to quickly and easily pinpoint the right purification method for your application. Additional information about Labconco Water Purification System selection is available by calling 800-821-5525 or 816-333-8811.

Table of Contents

Overview	1-4
Selection Chart	5
WaterPro Softeners	6-7
Introduction	6
Features and Benefits	7
Specifications	7
Accessory	7
Dimensional Data	7
WaterPro RO Stations	8-13
Introduction	8
Features and Benefits	9
Specifications	10
Technical Specifications	11
Expendables	11
Accessories	11-13
Dimensional Data	13
WaterPro PS Polishing Stations	14-22
Introduction	14
Features and Benefits	15
Specifications	16-19
Technical Specifications	20
Expendables	21
Accessories	21
Dimensional Data	22
Plumbing Diagram	23
Water Glossary	24

Water Pure Enough For Laboratory Use

In the laboratory, tap water is not pure enough for experimental use. Analytical researchers are commonly concerned with elements and compounds in the parts per billion range. Life science research is often very sensitive to many contaminants, particularly heavy metals and dissolved organics. High performance liquid chromatography (HPLC) requires ultrapure water for calibration of detector base lines and elution of reverse phase columns. Trace element analysis requires water which is free of the elements being examined.

In response to the increasing sensitivity of their research, several professional organizations have established water quality standards. These groups include the American Chemical Society (ACS), the American Society for Testing and Materials (ASTM), the National Committee for Clinical Laboratory Standards (NCCLS), and the U.S. Pharmacopeia (USP). As an example, the NCCLS has specified three types of water — I, II, III — and Special Purpose, which are listed below with their intended uses.

NCCLS Water Types and Applications

Type I:

Test methods requiring minimal interference and maximum precision and accuracy: atomic absorption, flame emission spectrometry, ligand assays, trace metals, enzymatic procedures sensitive to trace metals, electrophoretic procedures, high sensitivity chromatographic procedures, fluorometric procedures, buffer solutions and standard solutions.

Type II:

Test methods in which the presence of bacteria can be tolerated: general reagents without preservatives, microbiology systems (not to be sterilized). Test methods for which requirements leading to the choice of Type I or Special Purpose waters do not apply: stains and dyes for histology, general reagents with preservatives and microbiology systems (to be sterilized).

Type III:

General washing and feedwater for producing higher grade water, as well as bacteriological media preparation.

Special Purpose:

Procedures requiring removal of specific contaminants: removal of pyrogens for tissue/cell cultures and removal of trace organics for HPLC.

Reproduced with permission of National Committee for Clinical Laboratory Standards, Villanova, PA.

A summary of the various Type I water quality standards and the factors used to establish them are listed below:

Type I Water Quality Standards

	NCCLS	ASTM
Resistivity ¹ , megohms-cm, at 25° C,	10.0	minimum 18.0
Conductivity ¹ , μ S/cm, maximum	0.1	0.056
Silicate, mg/l, maximum	0.05	.003
Particulate matter, μ m filter	0.22	0.2
Microorganisms, colony forming units per milliliter	10	see note 2

¹ Resistivity and conductivity of Type I water must be measured in-line. Measuring in a container will give inaccurate readings.

² For ASTM: Type IA water - 10/1000 ml
Type IB water - 10/100 ml
Type IC water - 100/10 ml

Contaminants and Water Testing

The five types of contaminants commonly found in water are:

1. Particulates
2. Dissolved inorganics (solids and gases)
3. Dissolved organics
4. Microorganisms
5. Pyrogens

PARTICULATES include silt, plumbing pipe debris and colloids. These suspended particles can plug filters, valves, tubing and reverse osmosis membranes. Particulates are visible as cloudiness or turbidity, and are detected using filtration and gravimetric means, or microscopic methods.

DISSOLVED INORGANICS include calcium and magnesium ions dissolved from rock formations (these two ions make water hard), gases such as carbon dioxide that ionize in water (carbon dioxide dissolves readily in water to make mildly acidic carbonic acid), silicates leached from sandy river beds or glass containers, ferric and ferrous ions from rusty iron pipes, chloride and fluoride ions from water treatment plants, phosphates from detergents, nitrates from fertilizers, and many others.

There are several tests for identifying specific dissolved inorganics. The simplest test is a direct measurement of electrical conductivity or resistivity. Most dissolved inorganics are either negatively charged (anionic) or positively charged (cationic), and transmit a current when a voltage is applied to electrodes inserted in the water. The more ions present, the greater the conductivity, or the lower the resistivity of the sample water.

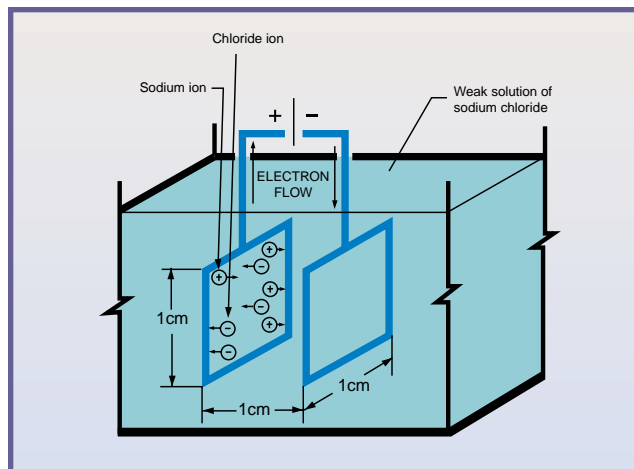

This figure shows the standard configuration of a conductivity cell and the movement of the anions (-) and cations (+) toward the charged poles.

Reprinted from *Handbook of Water Purification 1987* by courtesy of Walter Lorch, editor, and McGraw Hill, publisher.

Conductivity is expressed in microsiemens/cm and is used to measure water with a large number of ions. Resistivity is expressed in megohms-cm and is used in the measurement of water with few ions. Conductivity and resistivity are reciprocals of each other. Thus, at 25° C, 18.2 megohm water, which is the highest purity water obtainable with today's technology, has a conductivity of 0.055 microsiemen/cm.

Resistivity	0.1	1.0	10.0	18.2	megohm-cm
Conductivity	10.0	1.0	0.1	0.055	microsiemens/cm

DISSOLVED ORGANICS may include pesticides, herbicides, gasoline, and decayed plant and animal tissues. Dissolved organics may also include the plasticizers leached out of plumbing lines, fittings and storage tanks.

Note the sources of plasticizers — all are from improperly designed water purification systems. Thus, a water purification system must both remove the contaminants present in the feed-water, and be designed to minimize the addition of contaminants to the water.

The absence of dissolved organics is very important when performing analyses of organic substances in HPLC, gas chromatography, electrophoresis, and fluoroscopy, or in research involving tissue cultures. Total Organic Carbon (TOC) analyzers, which oxidize the organics and measure the CO₂ liberated, are used to determine organic levels in Type I water.

MICROORGANISMS constitute another group of contaminants found in water. Surface water may contain a wide variety of microorganisms, including bacteria, protozoa, algae and others. Since most laboratory water comes from municipal water treatment plants, which is extensively treated to remove microorganisms, the chief microbes of concern for water purification systems are bacteria.

REVERSE OSMOSIS can best be explained after understanding the natural process of osmosis. Osmosis is the movement of water across a semipermeable membrane from the less concentrated (purer) side to the more concentrated (saltier) side (A). This movement continues until the concentrations reach equilibrium or the pressure on the more concentrated side becomes high enough to stop the flow (B). Osmosis is the natural process by which water is drawn into a plant's root, or moved from one cell to another in our bodies.

If a pressure greater than the osmotic pressure is applied to the more concentrated solution, using a high pressure pump, water molecules are pushed back across the membrane to the less concentrated side, yielding purified water (C). This is the process of reverse osmosis.

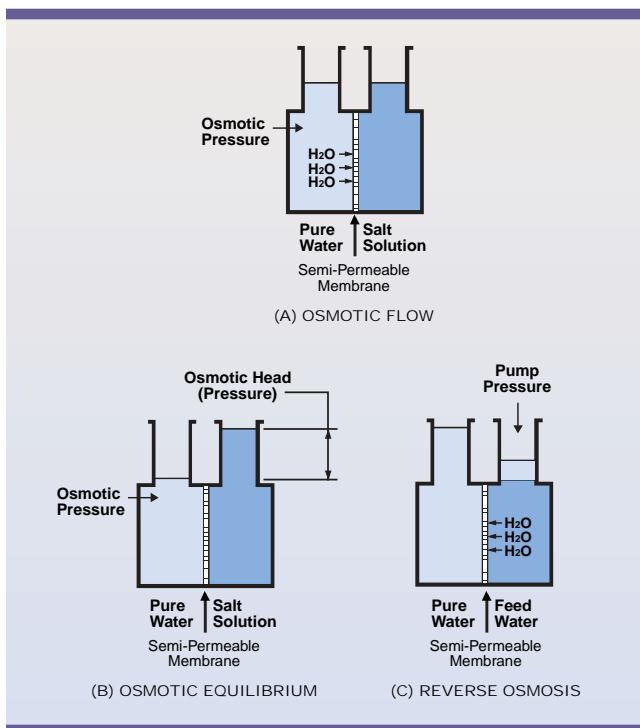

Reprinted from Handbook of Water Purification 1987 by courtesy of Walter Lorch, editor, and McGraw Hill, publisher.

Reverse osmosis typically removes 90-99% of most contaminants. A table of reverse osmosis performance characteristics follows:

Contaminant	% Removal Efficiency
Suspended solids	100
Bacteria	99.5
Viruses	99.5
Pyrogens	99.5
Organics, molecular weight > 250 Daltons	97-99.5
Monovalent inorganics	94-96
Divalent inorganics	96-98
Trivalent inorganics	98-99

Because of its exceptional purifying efficiency, reverse osmosis is a very cost effective technology for a water purification system. Because reverse osmosis removes a high percentage of contaminants, it is often used as a pretreatment process which significantly prolongs the life of the deionization "polishing" cartridges. A system which allows dispensing of the reverse osmosis water gives a source of high quality pre-purified water suitable for many routine laboratory purposes.

ACTIVATED CARBON FILTRATION removes chlorine by chemisorption and dissolved organics by adsorption and is often found at two places in a water purification system. Because thin film composite reverse osmosis membranes are sensitive to chlorine, and to a lesser degree, fouling from dissolved organics, activated carbon is often placed before the RO membrane to remove these contaminants.

A granular activated carbon filter is also often placed in the polishing loop of a water purification system to remove trace amounts of dissolved organics.

MICROPOROUS FILTRATION or submicron filtration uses a membrane or hollow fiber with an absolute pore size of 0.2 micron that prevents any contaminant larger than 0.2 micron from passing through it. The submicron filters retain carbon fines from the carbon cartridge, resin fragments from the deionization cartridges and any bacteria that may have entered the system.

NCCLS considers water to be particulate-free when it has been passed through a 0.2 micron filter. Microporous membranes are considered to be indispensable elements of a water purification system, unless they are replaced by an ultrafilter.

ULTRAFILTRATION uses a membrane very similar in design to reverse osmosis systems, except that the ultrafilter's pores are slightly larger. The ultrafilter is used to remove pyrogens from the purified water.

Since a high percentage of the water brought to the ultrafilter passes through it, it will eventually plug if not maintained. In a properly designed system, the ultrafilter is regularly and tangentially washed free of contaminants. With this type of design, ultrafiltration is an outstanding technology for ensuring very consistent ultrapure water quality.

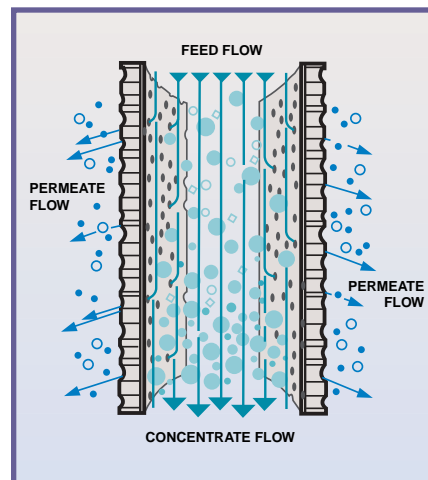

Crossflow filtration in an ultrafilter showing pyrogens and particles being retained, while only water molecules pass through the pores.

Courtesy of OSMONICS, INC., Minnetonka, MN, USA.



ULTRAVIOLET OR PHOTO OXIDATION uses ultraviolet radiation at the biocidal wavelength of 254 nanometers to eliminate bacteria from the system. It also cleaves and ionizes certain organics at 185 nanometers for subsequent removal by the deionization and organic adsorption cartridges in the polishing loop.

The Right Purification Method For You

Choosing the right purification method for your laboratory depends on several factors.

1. Consider your application. For example, are you performing HPLC, Atomic Absorption, Mass Spectrometry or Gas Chromatographic Analyses? If you answered "yes" to any of these applications, then you may need a system that uses activated carbon filtration, organic adsorption and deionization technologies. Does your work require that your water be bacteria-free? If yes, then you must choose a system that incorporates microporous filtration or ultrafiltration.
2. Consider the quantity of water used each day. Choose a system that best meets your requirements.
3. Consider the quality of your feedwater. Identifying the contaminants and their concentrations present in your feedwater with the free WaterProfile™ analysis kit will help you select the appropriate water purification system for your needs.

Labconco's Approach To Water Purification

Labconco's water purification systems were designed to directly address the shortcomings found in traditional approaches to water purification. The concepts that Labconco brings to the field of water purification, along with our high standards for quality construction of laboratory equipment, excellent service and one year warranty are:

Recirculation throughout the polishing system, to the dispenser, to minimize bacterial buildup found in stagnant water.

Unique dispensing gun for sensitive one-hand control of flow rates and enhanced flexibility.

Informative diagnostic panels to relay system status and performance.

Highest quality materials, including spiral wound thin film composite reverse osmosis membranes, nuclear grade resins and all inert materials of construction in the water pathway.

To Serve You

The Labconco Sales Support Center is open 7 a.m. to 6 p.m. Monday-Friday central time to provide immediate assistance. Just call 800-821-5525 or 816-333-8811 for answers to questions about applications, product selection, specifications and service.

Should you require assistance after normal business hours or on weekends, a recording on our toll-free number provides instructions for accessing our customer service emergency hotline.

Let Us Help You Choose A Water Purification System To Meet Your Specific Laboratory Requirements



The free WaterProfile water analysis kit is a good first step. To request this service, simply complete the WaterProfile postcard located in the back pocket of this catalog or call Labconco Customer Service at 800-821-5525 or 816-333-8811. The WaterProfile Kit includes a questionnaire to help pinpoint your application needs, a bottle to fill with your feedwater (tap or pretreated) and a label and packaging for returning the kit to Labconco. After we conduct a series of diagnostic tests, you receive a report detailing your tap water quality and recommendations on the appropriate WaterPro Water Purification System for your laboratory.



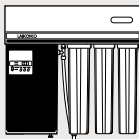
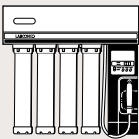
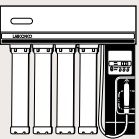
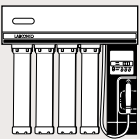
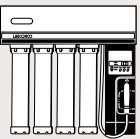

Selection Guide

WATERPRO PS POLISHING STATION						
	WaterPro Softener	WaterPro RO Station	General Chemistry	HPLC	UF	HPLC/UF Hybrid
Water Technologies						
Softening	•					
Carbon Filtration		•	•	•	•	•
Reverse Osmosis		•				
Deionization			•	•	•	•
Organic Adsorption				•		•
Ultrafiltration					•	•
Ultraviolet Oxidation					•	•
Microporous Filtration			Optional	Optional	Optional	Optional
Mounting						
Wall	•	•	•	•	•	•
Bench		Accessory	Accessory	Accessory	Accessory	Accessory
Mobile		Accessory	Accessory	Accessory	Accessory	Accessory
Dispensing						
Typical Flow Rate – Maximum Liter/Min. (at 25° C)	N/A	1.0	1.8 (1.2*)	1.8 (1.2*)	1.1 (1.0*)†	1.8/1.1 (1.1*/1.0*)†**
Minimum Feedwater Quality	Tap	Tap	Pretreated (100µS)	Pretreated (100µS)	Pretreated (100µS)	Pretreated (100µS)
Gun and Valve	n/a	Accessory	•	•	•	•
Valve Only	n/a	•	•	•	•	•
Applications						
<i>General Lab Procedures</i>						
Pretreatment for:						
Glassware Washing	•					
RO	•					
Deionization System		•				
Glassware Rinsing		•	•	•	•	•
Qualitative Applications			•	•	•	•
Buffer Solution Prep		•	•	•	•	•
Standard Solution Prep		•	•	•	•	•
<i>Inorganic Analyses</i>						
Ion Chromatography			•	•	•	•
Inductively Coupled Plasma/ Mass Spectroscopy			•	•	•	•
Atomic Absorption			•	•	•	•
Flame Emission Spectroscopy			•	•	•	•
Trace Metal Analysis			•	•	•	•
<i>Organic Analyses</i>						
Liquid Chromatography				•		•
HPLC				•		•
Gas Chromatography				•		•
Electrophoresis				•		•
Total Organic Carbon				•		•
<i>Life Sciences</i>						
Tissue Culture					•	•
Clinical					•	•
General Microbiology		•			•	•
General Immunology		•			•	•
Recombinant DNA					•	•

* rate with optional Hollow Fiber Final Filter installed

† actual flow rates for ultrafiltered models could vary as much as ±15% due to membrane navigation

** rate through dispensing valve/rate through dispensing gun



WaterPro® Softeners Protect Water Purification Systems

The wall-mountable WaterPro Softener is the ideal partner for any reverse osmosis water purification system such as Labconco's WaterPro RO Station. The Softener extends the life of the reverse

osmosis membrane by protecting it from scaling due to hard water. The WaterPro Water Softener may also be connected to Labconco's SteamScrubber or FlaskScrubber Glassware Washers to provide softened water to any cycle. Softened water protects washer components from scaling and also helps activate detergent.

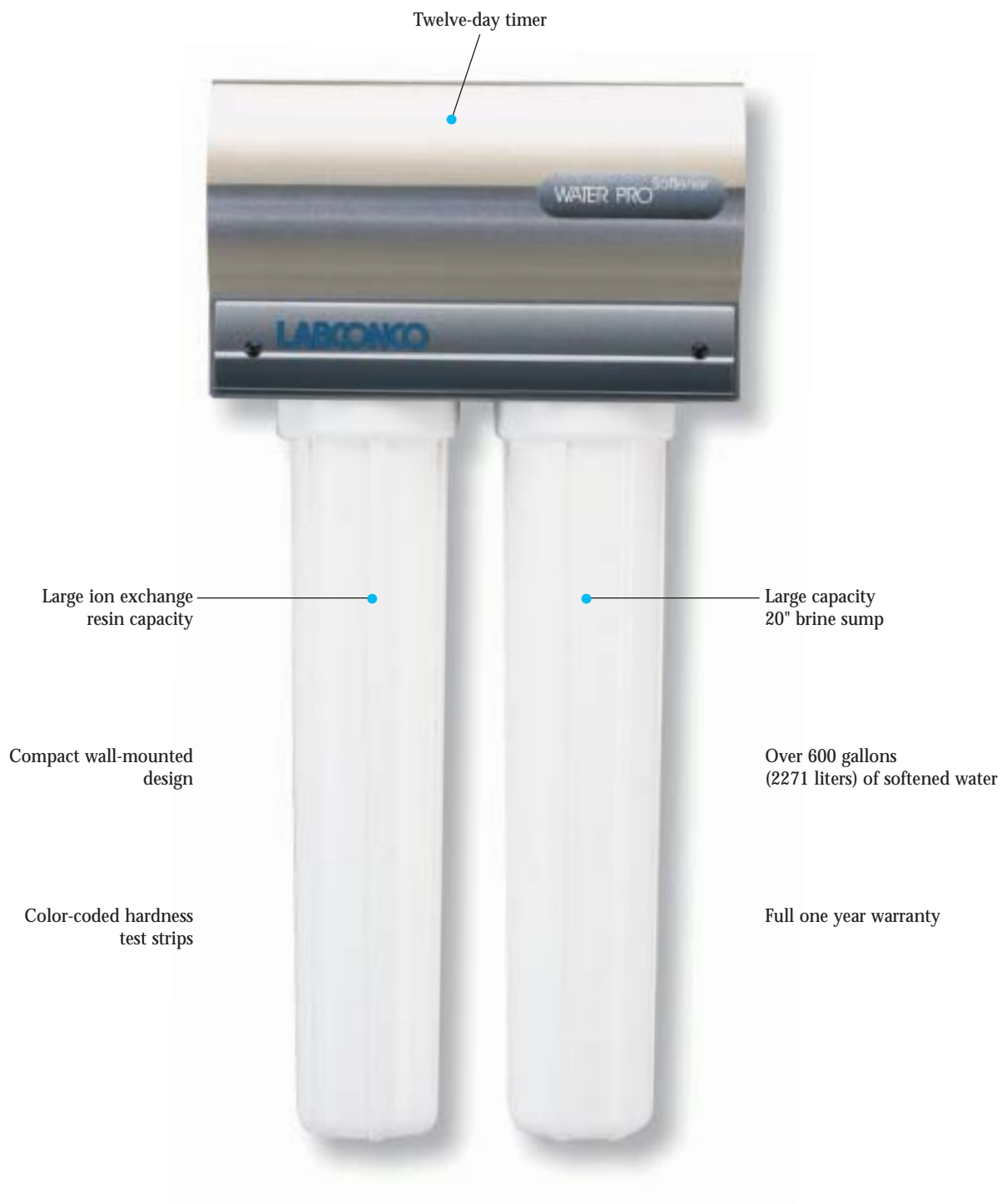



WaterPro Softener Model #90733-00

Twelve-day timer automatically initiates resin regeneration. The timer also allows you to specify when regeneration should occur, such as overnight or during a non-peak time.

Large capacity 20" brine sump requires infrequent filling. When two-thirds full, the brine sump holds 4.8 pounds of crystalline softener salt, which provides three regenerations before refilling is necessary.

Large ion exchange resin capacity provides years of efficient water softening.

Over 600 gallons (2271 liters) of softened water at 8 grains of hardness are provided before salt replacement is necessary. The capacity is well-suited to the requirements of an average laboratory.

Compact wall-mounted design saves space.

Color-coded hardness test strips included with Softener allow easy 15 second water quality tests.

Full one year warranty is provided against defects in materials and workmanship.

Specifications

90733-00 WaterPro Softener.

Cabinet. 14 3/8" w x 7 3/4" d x 29 1/8" h (36.5 x 19.7 x 74 cm). Constructed of epoxy-coated steel with Type 304 stainless steel front panel. Includes 12-day timer. Six feet of drain tubing and five feet of polyethylene feedwater tubing are provided. Six color-coded hardness test strips, mounting template and hardware are included.

Sumps. Constructed of white polypropylene. Includes sump for ion exchange resin and sump for 4.8 pounds of crystalline salt. A spanner wrench is provided for sump removal. Ion exchange resin is provided. **Salt is not included.**

Electrical requirements. 115 volts, 60 Hz, 1 amp AC. Includes an 8-foot, 3-wire cord with plug. Shipping weight 65 lbs. (29.5 kg)

*90733-01 WaterPro Softener.

Specifications are the same as for 90733-00 except for the following changes.

Electrical Requirements. 230 volts, 50 Hz, 0.5 amp AC. Includes an 8-foot, 3-wire cord. **An electrical plug is required.**

Accessory

90964-00 Replacement Color-Coded Hardness Test Strips, package of 10. Shipping weight 0.5 lb. (0.23 kg)

*International electrical configuration

Dimensional Data

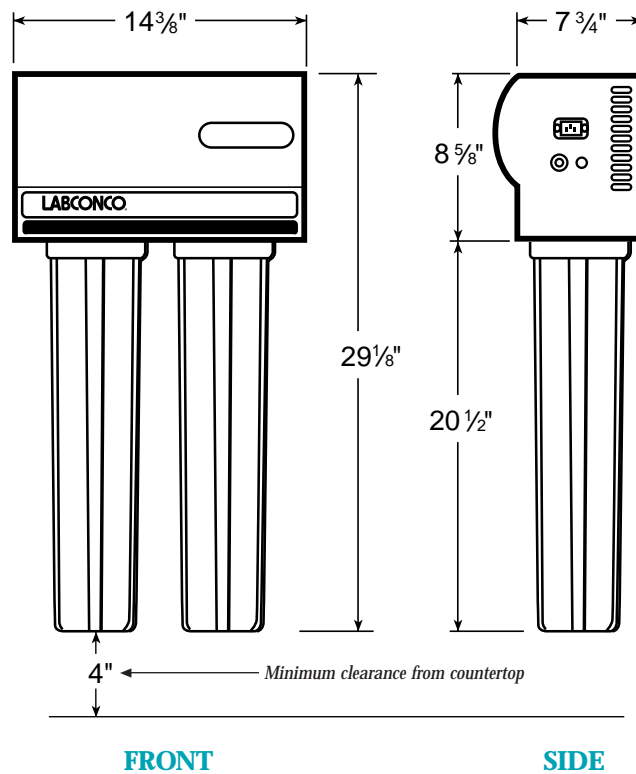



WaterPro RO Stations

WaterPro® RO Stations produce Type III water at a rate of 1 liter per minute

The NEW WaterPro® RO Station with its large capacity filters and membrane delivers high-quality reverse osmosis (RO) purified Type III water* at a typical rate of 1 liter per minute (at inlet water temperature of 25° C). RO purified water is ideal for laboratory applications such as reagent preparation and glassware rinsing.

Water may be dispensed manually from a valve or an optional gun. Water from the valve may also be activated automatically by using the exclusive timed dispense feature that allows for unattended operation. Simply set the timer up to 99.9 minutes,

press the dispense button and walk away. The valve dispenses until the set time has expired.

The WaterPro RO includes an outlet port for connection to a laboratory glassware washer such as Labconco's SteamScrubber® or FlaskScrubber®. With its 17 liter tank, the WaterPro RO holds ample volume to supply the Labconco washer with pure water for its final two rinse cycles.

The WaterPro RO may also be used to pretreat feedwater for ultimate purification by a polishing system. The WaterPro RO may be easily connected to any Labconco WaterPro PS Polishing Station to allow dispensing of both RO and Type I water.

* Meets NCCLS Type III water standards with feedwater purity of 100 µs or better.

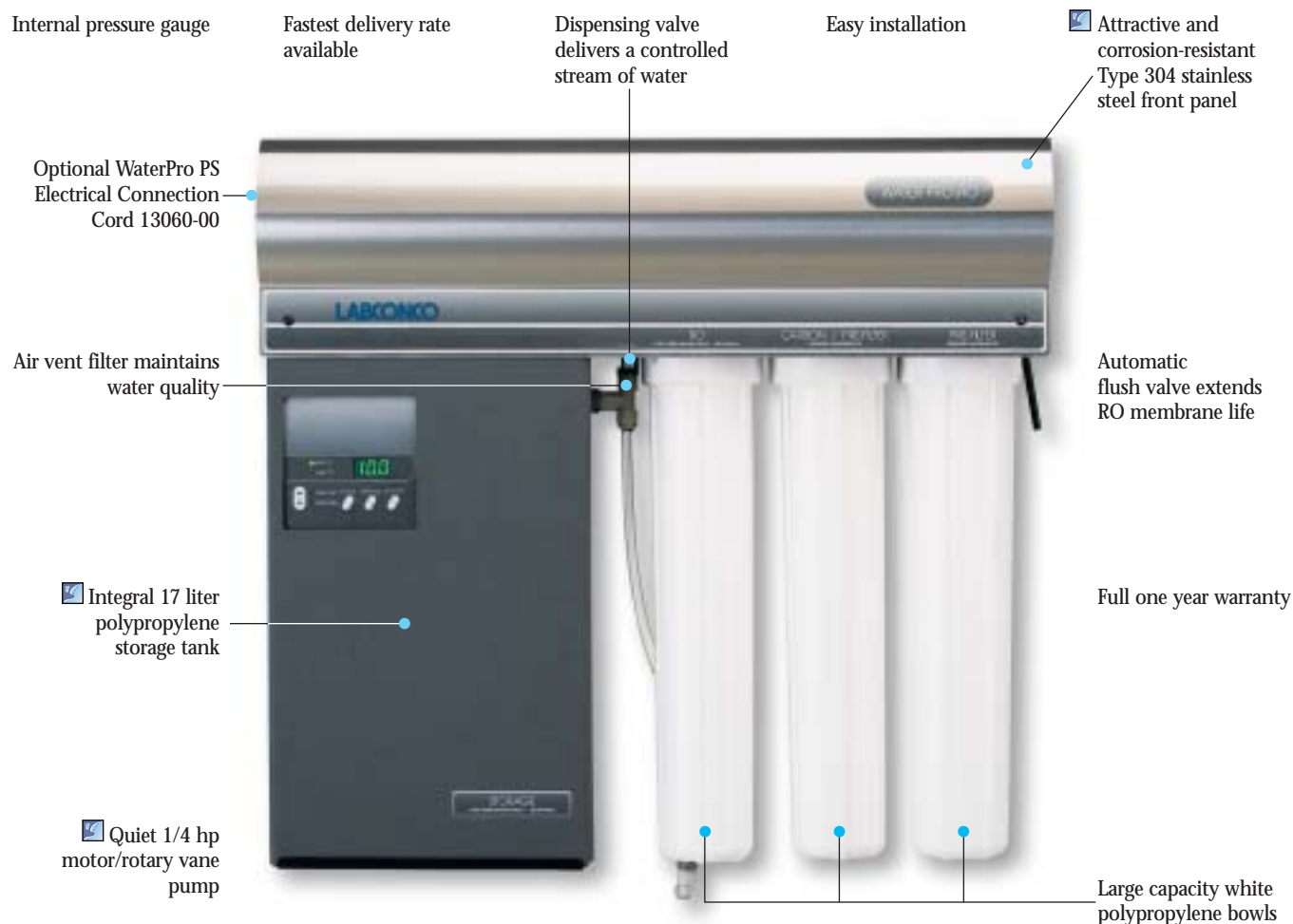

Optional Dispensing Gun 91131-00



User-friendly control panel with digital display

Timed dispense



 Exclusive feature



WaterPro RO Station 90750-00 with optional dispensing gun 91131-00

Fastest delivery rate available. The WaterPro RO supplies pure water to the dispensing valve or optional gun at a typical rate of 1 liter per minute. From the storage tank, purified water typically flows at 8.7 liters per minute (gravity fed) or may be drawn into the WaterPro PS Polishing Station, SteamScrubber or FlaskScrubber by the polishing station or washer pump.

Large capacity white polypropylene bowls require infrequent filter changes. Threaded heads seal tightly to eliminate leaks. The three bowls accommodate one 5-6 micron prefilter, one carbon filter and one RO membrane (expendables must be ordered separately).

☑ **Attractive and corrosion-resistant Type 304 stainless steel front panel.** The epoxy-coated steel cabinet with stainless steel front panel houses the motor and pump for quiet operation.

☑ **Timed dispense for unattended operation.** When TIME DISP. is selected, time of water delivery may be set in minutes from 0 to 99.9 with the increase/decrease control button. Pressing the DISPENSE switch initiates the water delivery from the dispensing valve. Water delivery automatically ceases when time expires, facilitating unattended operation.

User-friendly control panel with digital display. Touch-pad controls allow the user to select and view water quality (1 to 999 microseimens), water temperature (° C) or timed dispense (0 to 99.9 minutes) on the LED display. An indicator light glows green when the parameter selected is displayed. Pressing the ON/OFF switch to ON lights the LED display. A TANK FULL indicator light glows green when the storage tank has reached capacity.

☑ **Quiet 1/4 hp motor/rotary vane pump** operates at less than 56 decibels. A low pressure switch prevents pump damage.

☑ **Integral 17 liter polyethylene storage tank** includes an outlet port for connection to a polishing station and/or a glassware washer.

Air vent filter maintains water quality by removing bacteria and other particulate contaminants prior to air entering the storage tank.



WaterPro RO Station 90750-00

Easy installation. A tap water line, drain, electrical outlet and expendables are needed for operation. The WaterPro RO Station may be mounted on the wall or other vertical surface. An optional support stand allows the system to be bench mounted.

Automatic flush valve extends RO membrane life. It maintains water purity by automatically initiating the purification process, flushing the RO membrane and tank for three minutes after each 12 hour period of inactivity.

Dispensing valve delivers a controlled stream of water. Its 3/8" OD stem adapter allows connection to tubing. The DISPENSE button on the front panel electrically controls water delivery.

Internal pressure gauge provides readings from 0 to 160 psi of RO-purified water and is accessible by removing the front panel. It is designed for use when troubleshooting. A back pressure RO membrane relief valve is preset to 150 psi.

CE marking. Model 90750-02 for operation on 230 volt, 50 Hz conforms to electrical safety and electromagnetic compatibility standards as set by the European Community.

Full one year warranty is provided against defects in materials and workmanship.

Optional Dispensing Gun 91131-00 is offered as an accessory. The trigger on the gun may be operated with one hand and provides drop-by-drop control or locks to provide a continuous stream of water.

Optional WaterPro PS Electrical Connection Cord 13060-00 is offered as an accessory. When mounting the WaterPro PS Polishing Station on the left side of the WaterPro RO Station, this cord allows electrical connection between the two so that only one electrical outlet is required.

☑ *Exclusive feature*

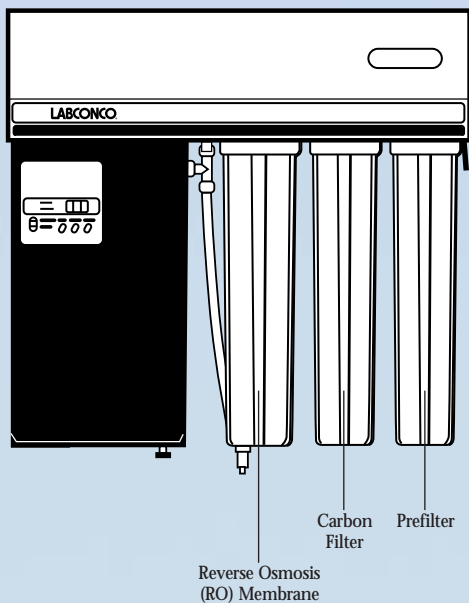

Purification Technologies/Features:

Prefilter

The prefilter removes particulates larger than five microns from the feedwater protecting the reverse osmosis membrane.

Carbon Filter

An activated carbon filter removes organics and chlorine from the feedwater. Provides protection for the reverse osmosis membrane.

Reverse Osmosis (RO) Membrane

A thin film composite membrane removes up to 99% of inorganics, organics and colloids.

Specifications

90750-00 WaterPro RO Station

Bowls. Constructed of white polypropylene. Bowls are included for one prefilter, one carbon filter and one reverse osmosis membrane. A spanner wrench is provided for filter changes. Cartridges are not included. **Refer to Prefilter/Carbon Filter Kit 90672-01 and Reverse Osmosis Membrane 90787-00.**

Cabinet. Overall dimensions (including bowls): 31 1/8" w x 7 23/32" d x 30 3/8" h (79 x 19.6 x 77.2 cm). Constructed of epoxy-coated steel with Type 304 stainless steel front panel. Includes 1/4 hp motor/rotary vane booster pump, RO membrane back pressure relief valve preset to 150 psi, internal pressure gauge with range from 0 to 160 psi, automatic flush valve, air vent filter, tank check valve and hardware for wall mounting.

Control Panel. Includes ON/OFF switch; LED display; μ S, TEMP ° C, TIME DISP. and TANK FULL indicator lights; DISPENSE switch for water delivery control from valve; MODE switch for selecting LED display; and increase/decrease switch for setting dispensing time from 0 to 99.9 minutes. Depending on mode selected, LED display shows actual water quality from 1 to 999 microseimens (μ S), actual water temperature in ° C or dispense time in minutes.

Dispensing Valve. Typically delivers 1 liter/minute of RO-purified water by pressing the DISPENSE switch or activating TIME DISP. If TIME DISP. is activated, water dispensing from the valve automatically shuts off once user-set time has elapsed. Includes hose barb fitting for 3/8" ID tubing.

Electrical Requirements. 115 volts, 60 Hz, 12 amps AC. Includes an 8-foot, 3-wire cord and plug.

Plumbing Connections. Feedwater line should be 3/8" OD rigid plastic tubing or 1/4" ID flexible tubing. Drain lines from the flush valve and RO station are provided.

Storage Tank. Constructed of polyethylene with 17 liter capacity. Housing is thermoplastic and epoxy-coated steel. Includes outlet port for 1/2" OD plastic tubing for connection to polishing station and/or glassware washer. Shipping weight 100 lbs. (45 kg)

*90750-02 WaterPro RO Station

Specifications are the same as for 90750-00 except for the following changes.

Agency Approval. Station conforms to European Community electrical safety and EMC directives and has CE conformity markings.

Electrical Requirements. 230 volts, 50 Hz, 6 amps AC. Includes an 8-foot, 3-wire cord. **An electrical plug is required.**

* International electrical configuration



Technical Specifications

Feedwater Requirements

Maximum inlet pressure	100 psi
Minimum inlet pressure	30 psi
Flow rate	5.5 liters/min. (1.5 gal./min.)
Temperature	10-35° C (50-95° F)
pH	4-10
Maximum Silt Density Index	5 SDI
Turbidity	≤ NTU
Langelier Saturation Index	Negative (If positive, softener pretreatment is required)

Maximum Ion Concentrations

Iron (total)	≤0.1 ppm (mg/liter)
Manganese	≤0.1 ppm
Chlorine	≤0.5 ppm

Typical Dispensing Rates*

From RO (valve or gun)	Typically 1 liter/ minute at 25° C and conversion rate of approximately 20%
From storage tank	8.7 liters/minute (gravity fed)
Drain Requirement	Must handle 5 liters/min.

* depending on feedwater flow rate and pressure

Expendables

- 90672-01 **Prefilter/Carbon Filter Kit required for operation.** Includes Prefilters (3) and Carbon Filters (3), for initial start-up and two filter changes. Shipping weight 10 lbs. (4.5 kg)
- 90787-00 **Reverse Osmosis Membrane required for operation.** Shipping weight 6 lbs. (2.7 kg)

Accessories

- 13060-00 **WaterPro RO/PS 125/230 Volt, 10 amp Electrical Connection Cord** Three wire cord with a plug on both ends allows electrical connection between the left side of the WaterPro RO Station and the right side of the WaterPro PS Polishing Station. The cord and plug included with the WaterPro RO Station then plugs into an electrical receptacle to supply power to both water systems. For use with either 115 volt, 60 Hz WaterPro RO and PS models or 230 volt, 50 Hz WaterPro RO and PS models. Shipping weight 2 lbs. (0.9 kg)
- 91132-00 **WaterPro RO/PS Mobile Stand** Adds portability to your WaterPro RO Station and WaterPro PS Polishing Station. Constructed of glacier white epoxy-coated



steel with 2" diameter hard rubber casters. Includes hardware to mount the WaterPro RO and WaterPro PS back-to-back on the stand. If desired, a single WaterPro RO may be mounted on one side or two WaterPro RO Stations may be mounted back-to-back. Dimensions (with WaterPro RO Station and WaterPro PS Station attached): 31 1/8" w x 23 1/2" d x 43 1/2" h (79.1 x 59.1 x 110.5 cm). Shipping weight 40 lbs. (18.1 kg)

- 90774-00 **Support Stand** For converting wall-mounted WaterPro RO Stations to bench-mounted. Rests on a countertop or other horizontal surface. Constructed of glacier white epoxy-coated steel. Includes hardware to mount the WaterPro RO to the stand. Dimensions (with WaterPro RO Station attached): 31 1/8" w x 16 1/8" d x 35 1/3" h (79 x 41 x 90 cm). Shipping weight 20 lbs. (9 kg)

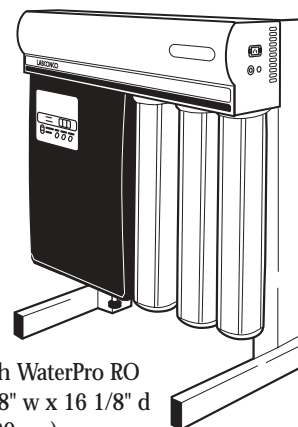



WaterPro RO Stations

- 91131-00 **Dispensing Gun** Provides additional means to dispense water from the WaterPro RO Station. Trigger permits operation with one hand and provides precise drop-



by-drop control or locks to provide a continuous stream of water. Includes gun attached to a 6-foot hose, charcoal epoxy-coated steel gun rest and mounting hardware. Shipping weight 5 lbs. (2.3 kg)

- 91000-00 **70 Liter Storage Tank** Connects to the WaterPro RO Station to provide additional storage capacity for RO-purified water and means to deliver RO-purified water from three outlets to destinations such as a polishing station and glassware washer. It uses a gravity feed sys-



tem for water delivery. The 70 liter polyethylene tank has one 3/4 NPT female port and two 3/8" ball valves with 3/8" Celcon* female Guest** fittings. The tank includes 6 feet of polyurethane tubing for connection to the WaterPro RO Station, a 0.3 micron vent filter to help prevent airborne bacterial contamination of the tank, a float switch to prevent the WaterPro RO Station from overfilling the tank, a fill valve wired in series with the float switch that activates when a drop

in water level is detected, and two check valves that direct water to drain if the water level exceeds normal level. The tank has a glacier white epoxy-coated steel support stand so that it may stand alone up to 6 feet away from the WaterPro RO Station. For 115 volt, 60 Hz, 1 amp operation. Includes an 8-foot, 3-wire cord

Storage Tank Dispensing Rates†

from 3/4 NPT female port	up to 26 liters/min. (gravity fed)
from one 3/8" ball valve	up to 2.1 liters/min. (gravity fed)
from both 3/8" ball valves	up to 3.6 liters/min. (gravity fed) (combined rate)
Drain Requirement	Minimum 1.5 liters/min.

and plug. Dimensions: 32 7/8" w x 14 3/8" d x 26" h (83.5 x 36.5 x 66 cm). Shipping weight 80 lbs. (36.3 kg)

- 91000-01 **70 Liter Storage Tank** Same as 91000-00 except for 230 volt, 50/60 Hz, 0.5 amp operation. Includes an 8-foot, 3-wire cord. **An electrical plug is required.**
- 91010-00 **70 Liter Storage Tank with Dispensing Gun** Connects to the WaterPro RO Station to provide additional storage capacity for RO-purified water and means to deliver RO-purified water from four outlets to destinations such as a polishing station and glassware washer. It uses a gravity feed system for water delivery from two 3/8" ball valves with 3/8" Celcon female Guest fittings. It uses a 1/4 hp rotary vane pump for 24 psig pressurized water delivery to a dispensing gun and a 3/8 NPT female port. The dispensing gun includes a 6-foot hose, a charcoal epoxy-coated steel gun holder for attachment to the WaterPro RO Station and mounting hardware. The gun permits operation with one hand provides precise drop-by-drop control or locks to provide a continuous stream of water. The pump also provides constant 5.4 liter/minute recirculation of the water in the tank to minimize bacterial growth. The 70 liter polyethylene tank includes 6 feet of polyurethane tubing for connection to the WaterPro RO Station, a 0.3 micron vent filter to help prevent airborne bacterial contamination of the tank, a float switch to prevent the WaterPro RO Station from overfilling the tank, a fill valve wired in series with the float switch that activates when a drop in water level is detected, and two check valves that direct water to drain if the water level exceeds normal level. The tank has a glacier white epoxy-coated steel support stand so that it may stand alone up to 6 feet away from the WaterPro RO Station. For 115 volt, 60 Hz, 6 amp operation. Includes an 8-foot, 3-wire cord and plug. Dimensions: 32 7/8" w x 14 3/8" d x 26" h (83.5 x 36.5 x 66 cm). Shipping weight 95 lbs. (43 kg)

* Celcon® is a registered trademark of Hoechst Celanese.

** John Guest USA, Inc., Wayne, NJ.

† Dispensing rates listed are rates achieved when other ports and/or valves are plugged. Actual rates will vary depending on water demand from other ports and dimensions of fittings and connecting tubing used.



WaterPro RO Stations

Storage Tank Dispensing Rates†

from dispensing gun	up to 2.0 liters/min. (at 24 psig)
from one 3/8" NPT female port	up to 6.5 liters/min. (at 24 psig)
from one 3/8" ball valve	up to 2.1 liters/min. (gravity fed)
from both 3/8" ball valves	up to 3.6 liters/min. (gravity fed) (combined rate)
Drain Requirement	Minimum 1.5 liters/min.

91010-01 **70 Liter Storage Tank** Same as 91010-00 except for 230 volt, 50/60 Hz, 3 amp operation. Includes an 8-foot, 3-wire cord. **An electrical plug is required.**

† Dispensing rates listed are rates achieved when other ports and/or valves are plugged. Actual rates will vary depending on water demand from other ports and dimensions of fittings and connecting tubing used.

Dimensional Data

WaterPro RO Station

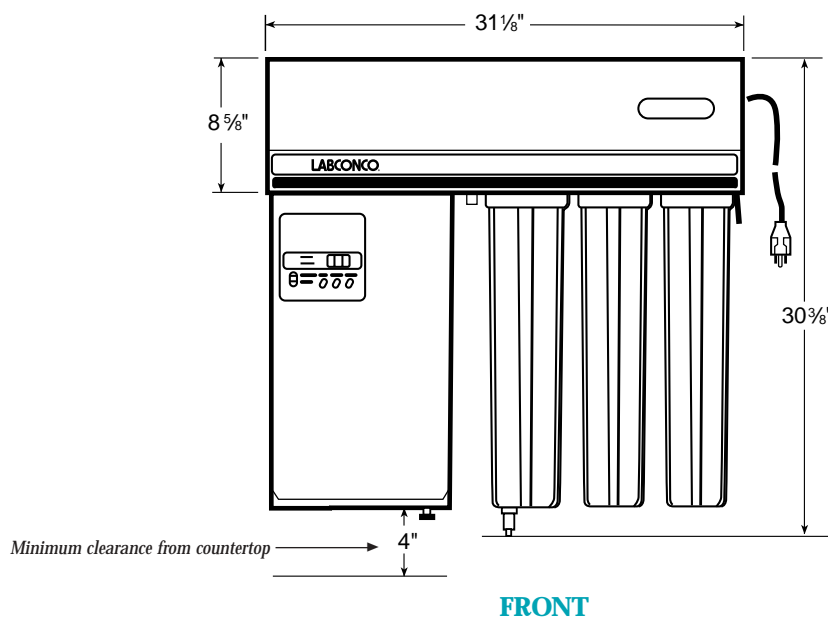

WaterPro RO Station with Optional Support Stand

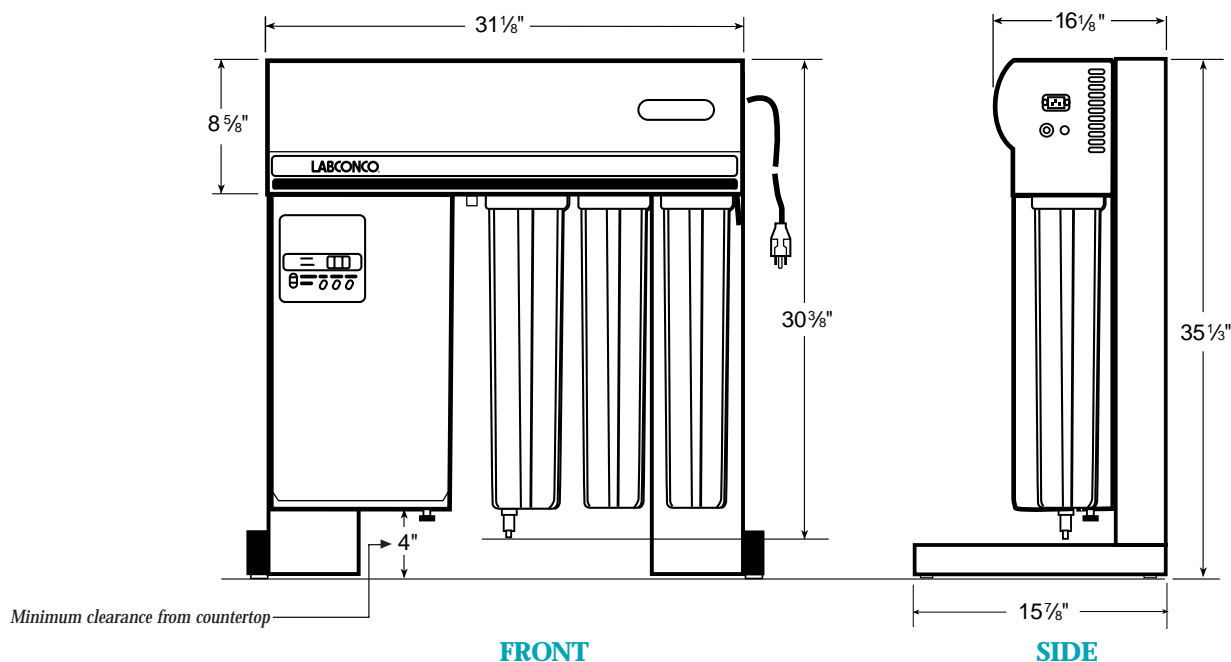



WaterPro PS Polishing Stations

WaterPro® PS Polishing Stations include exclusive timed dispensing feature for unattended operation

The WaterPro PS Polishing Stations deliver Type I water, up to 18.2 megohm-cm, from the dispensing valve or optional dispensing gun at a typical rate of 1.8 liters per minute depending on feed-water flow rate and pressure, and installed purification modules.

The new control panel includes a timed dispense feature that allows unattended dispensing of pure water. The risk of overfilling is virtually eliminated because the dispenser shuts off automatically once user-set time has elapsed.

The polishing stations have been redesigned into a sleek cabinet featuring stainless steel front panel and built-in dispensing center for a smaller overall footprint and easier installation. The large capacity bowls are made of unpigmented virgin natural polypropylene, an inert material that will not add impurities to the water.

Labconco has designed WaterPro PS Stations with the right combinations of purification technologies to meet your needs. Choose from specialized stations for general chemistry, analytical, life science or combination usage. In addition, models designed for general chemistry may be upgraded with additional purification modules at a later time for use in analytical or life science applications.

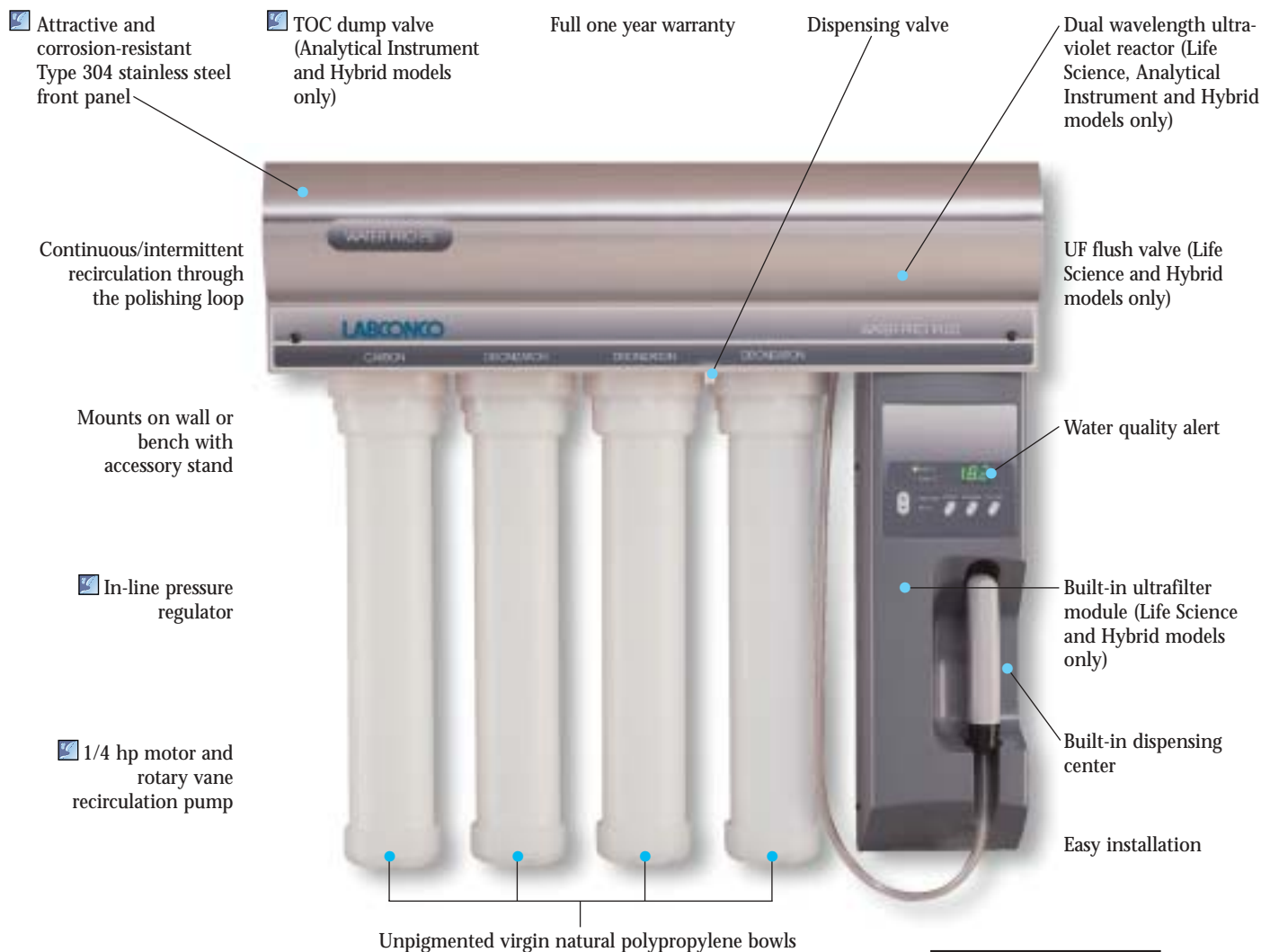

Deluxe dispensing gun (Pistol models only)

User-friendly control panel with digital display

Timed dispense

Exclusive feature





WaterPro PS Polishing Stations



WaterPro PS Polishing Station 90005-00 on Support Stand 90774-00



WaterPro PS Pistol Polishing Station 90005-01 on Support Stand 90774-00

User-friendly control panel with digital display. Touch-pad controls allow the user to select and view actual water quality (megohm-cm), water temperature ($^{\circ}$ C), timed dispense (minutes) or resistivity set point (megohm-cm) on the LED display. Pressing the ON/OFF button to ON lights the LED display. Pressing the ON/OFF button to OFF sets continuous recirculation to intermittent operation.

☑ Timed dispense for unattended operation. When TIME DISP. is selected, time of water delivery may be set in minutes from 0 to 99.9 with the increase/decrease control button. Pressing the DISPENSE button initiates the water delivery from the dispensing valve. Water delivery automatically ceases when time expires, allowing for unattended operation.

Water quality alert. When SET PT. is selected, resistivity set point of less than 16 may be selected with the increase/decrease control button. The LED flashes the actual water quality in megohm-cm to alert the user when water quality falls below set point.

Unpigmented virgin natural polypropylene bowls. Bowl material has no impurities to contaminate the water ensuring low TOC levels. The large capacity bowls require infrequent cartridge changes.

Built-in dispensing center. Compact, low profile design incorporates the dispensing center in the polishing station. On Pistol™ models, the dispensing center contains the gun while the dispensing valve is located on the polishing station. On models without gun, the dispensing center contains the valve. An optional Hollow Fiber Final Filter may be attached to the valve or gun to remove bacteria at the dispensing point.

☑ Attractive and corrosion-resistant Type 304 stainless steel front panel. The epoxy-coated steel cabinet with stainless steel front panel houses the pump and motor which are isolated for quiet operation.

Dual wavelength ultraviolet reactor (Life Science, Analytical Instrument and Hybrid models only). A UV light with dual wavelengths of 185 and 254 nm ensures both low TOC levels and bacteria free water.

☑ Exclusive feature

Built-in ultrafilter module (Life Science and Hybrid models only). A module located in the cabinet houses the ultrafilter, freeing the fourth bowl for an additional deionization cartridge. Additional cartridge capacity allows for less frequent filter changes.

CE marking. All 230 volt, 50 Hz models conform to electrical safety and electromagnetic compatibility standards as set by the European Community.

Easy installation. Plumbing lines are logically positioned and clearly labeled for mistake-proof installation. Mounts on wall or on bench with accessory support stand.

☑ 1/4 hp motor and rotary vane recirculation pump is directly coupled for quieter operation than smaller gear-type pumps.

☑ In-line pressure regulator protects the system from excessive water pressure and ensures that inlet water enters the system at optimum pressure (up to 100 psi). Feedwater may also be drawn from non-pressurized (0 psi) sources such as a reservoir.

Deluxe dispensing gun (Pistol™ models only) gives precise delivery through its smooth tip. The gun is attached to a three-foot recirculating line for dispensing to bench-level locations. The tip can be detached and replaced by an optional Hollow Fiber Final Filter to remove bacteria at the dispensing point.

Continuous/intermittent recirculation through the polishing loop maintains water quality, minimizes bacteria growth and reduces rinse up time. Water is produced on demand; no storage tank is used.

☑ TOC dump valve (Analytical Instrument and Hybrid models only) allows a small portion of purified water to drain during intermittent recirculation, maintaining ultra low TOC levels and eliminating rinse up times.

UF flush valve (Life Science and Hybrid models only) maintains ultrafilter efficiency. The valve allows a small portion of the purified water to rinse the ultrafilter during intermittent recirculation for one minute every four hours. Rinsing extends the life of the ultrafilter, ensuring pyrogen-free water.

Full one year warranty is provided against defects in materials and workmanship.



Water Produced: Type I (up to 18.2 megohm-cm)

TOC: <10 ppb

Typical Dispensing Rate: 1.8 liters/minute

Typical Dispensing Rate with optional Hollow Fiber Final Filter: 1.2 liters/minute

Applications: atomic absorption, flame emission spectroscopy, trace metal analysis, buffer solutions, standard reagent solutions

Technologies Used: carbon filtration, deionization

Required Polishing Kit: 90471-01 (one carbon and three deionization cartridges)

Specifications

90005-00 WaterPro PS Polishing Station with dispensing valve

Bowls. 20 1/4" h (51.4 cm). Four bowls constructed of unpigmented virgin natural polypropylene for one carbon and three deionization cartridges. A spanner wrench is provided for filter changes. **Cartridges are not included. Refer to Polishing Kit 90471-01, page 21.**

Cabinet. 31 1/8" w x 7 23/32" d x 8 5/8" h (79.1 x 19.6 x 21.9 cm). Overall height including bowls: 28 7/8" (73.3 cm). Constructed of epoxy-coated steel with Type 304 stainless steel front panel. Includes 1/4 hp motor/rotary vane recirculation pump and water pressure regulator.

Continuous/Intermittent Recirculation. In the ON setting, the system continuously recirculates through the polishing loop. In the OFF setting, the system automatically starts and circulates water through the polishing loop for approximately 4 minutes every 2 hours to minimize rinse up time and bacteria growth.

Control Panel. Includes ON/OFF switch; LED display; MEG Ω, TEMP. ° C, TIME DISP. and SET PT. indicator lights; DISPENSE switch for water delivery control from valve; MODE switch for selecting LED display; and increase/decrease switch for setting time from 0 to 99.9 minutes or set point from 0 to 16 megohm-cm. Depending on mode selected, LED display shows actual water quality in megohm-cm, actual water temperature in ° C, dispense time in minutes, or water quality set point in megohm-cm, and flashes when quality drops below set point.

Dispensing Center. Constructed of pressure-formed thermoplastic.

Dispensing Valve. Located at the dispensing center, valve typically delivers 1.8 liters/minute of Type I water by pressing the DISPENSE switch or activating TIME DISP. Typical dispensing rate with optional Hollow Fiber Final Filter (not included) is 1.2 liters/minute. If TIME DISP. is activated, water dispensing from the valve automatically shuts off once user-set time has elapsed.

Electrical Requirements. 115 volts, 60 Hz, 7.5 amps AC. Unit includes an 8-foot, 3-wire cord and plug.

Plumbing Connections. Feedwater line should be 3/8" OD rigid plastic tubing or 3/8" ID flexible tubing. Drain port connection to 3/8" OD line is provided.

Shipping weight 60 lbs. (27.2 kg)

90005-01 WaterPro PS Pistol Polishing Station with dispensing gun and valve

Specifications are the same as for 90005-00 except for the following changes.

Dispensing Gun. Rests in the dispensing center and is attached to a 3-foot (7.6 cm) flexible recirculating line. The hand-held gun typically delivers 1.8 liters/minute of Type I water by depressing the trigger. Typical dispensing rate with optional Hollow Fiber Final Filter (not included) is 1.2 liters/minute.

Dispensing Valve. Located on the polishing station.

*90005-02 WaterPro PS Polishing Station with dispensing valve

Specifications are the same as for 90005-00 except for the following changes.

Agency Approval. Station conforms to European Community electrical safety and EMC directives and has CE conformity markings.

Electrical Requirements. 230 volts, 50 Hz, 4 amps AC.

*90005-03 WaterPro PS Pistol Polishing Station with dispensing gun and valve

Specifications are the same as for 90005-01 except for the following changes.

Agency Approval. Station conforms to European Community electrical safety and EMC directives and has CE conformity markings.

Electrical Requirements. 230 volts, 50 Hz, 4 amps AC.

* International electrical configuration

Pistol Model Shown

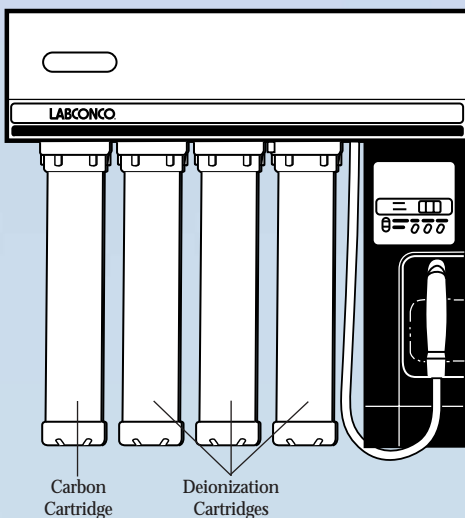

Purification Technologies/Features:

Carbon Filtration

An activated carbon filter removes organics and chlorine from the feedwater.

Deionization

Three polishing grade mixed bed deionization cartridges remove inorganic impurities.

Continuous/Intermittent Recirculation

Maintains water quality and inhibits bacteria growth throughout the system.

Optional Hollow Fiber Final Filter 90929-00

Removes bacteria at the dispensing valve or gun. Ordered separately.



Water Produced: Type I (up to 18.2 megohm-cm)

TOC: <5 ppb

Typical Dispensing Rate: 1.8 liters/minute

Typical Dispensing Rate with optional Hollow Fiber Final Filter: 1.2 liters/minute

Applications: HPLC, electrophoresis and fluoroscopy analysis

Technologies Used: carbon filtration, deionization, organic adsorption, ultraviolet exposure

Required Polishing Kit: 90472-01 (one carbon, two deionization and one organic adsorption cartridges)

Specifications

90006-00 WaterPro PS/HPLC Polishing Station with dispensing valve

Bowls. 20 1/4" h (51.4 cm). Four bowls constructed of unpigmented virgin natural polypropylene for one carbon, two deionization cartridges and one organic adsorption cartridge. A spanner wrench is provided for filter changes. **Cartridges are not included. Refer to Polishing Kit 90472-01, page 21.**

Cabinet. 31 1/8" w x 7 23/32" d x 8 5/8" h (79.1 x 19.6 x 21.9 cm). Overall height including bowls: 28 7/8" (73.3 cm). Constructed of epoxy-coated steel with Type 304 stainless steel front panel. Includes 1/4 hp motor/rotary vane recirculation pump and water pressure regulator.

Continuous/Intermittent Recirculation. In the ON setting, the system continuously recirculates through the polishing loop. In the OFF setting, the system automatically starts and circulates water through the polishing loop for approximately 4 minutes every 2 hours to minimize rinse up time and bacteria growth.

Control Panel. Includes ON/OFF switch; LED display; MEG Ω, TEMP. ° C, TIME DISP. and SET PT. indicator lights; DISPENSE switch for water delivery control from valve; MODE switch for selecting LED display; and increase/decrease switch for setting time from 0 to 99.9 minutes or set point from 0 to 16 megohm-cm. Depending on mode selected, LED display shows actual water quality in megohm-cm, actual water temperature in ° C, dispense time in minutes, or water quality set point in megohm-cm, and flashes when quality drops below set point.

Dispensing Center. Constructed of pressure-formed thermoplastic.

Dispensing Valve. Located at the dispensing center, valve typically delivers 1.8 liters/minute of Type I water by pressing the DISPENSE switch or activating TIME DISP. Typical dispensing rate with optional Hollow Fiber Final Filter (not included) is 1.2 liters/minute. If TIME DISP. is activated, water dispensing from the valve automatically shuts off once user-set time has elapsed.

Electrical Requirements. 115 volts, 60 Hz, 7.5 amps AC. Unit includes an 8-foot, 3-wire cord and plug.

Plumbing Connections. Feedwater line should be 3/8" OD rigid plastic tubing or 3/8" ID flexible tubing. Drain port connection to 3/8" OD line is provided.

TOC Dump Valve. Operates during intermittent recirculation to maintain a low TOC level <5 ppb.

Ultraviolet Reactor. Lamp with dual wavelengths of 185 and 254 eliminates trace organics and bacteria.

Shipping weight 60 lbs. (27.2 kg)

90006-01 WaterPro PS/HPLC Pistol Polishing Station with dispensing gun and valve

Specifications are the same as for 90006-00 except for the following changes.

Dispensing Gun. Rests in the dispensing center and is attached to a 3-foot (7.6 cm) flexible recirculating line. The hand-held gun typically delivers 1.8 liters/minute of Type I water by depressing the trigger. Typical dispensing rate with optional Hollow Fiber Final Filter (not included) is 1.2 liters/minute.

Dispensing Valve. Located on the polishing station.

*90006-02 WaterPro PS/HPLC Polishing Station with dispensing valve

Specifications are the same as for 90006-00 except for the following changes.

Agency Approval. Station conforms to European Community electrical safety and EMC directives and has CE conformity markings.

Electrical Requirements. 230 volts, 50 Hz, 4 amps AC.

*90006-03 WaterPro PS/HPLC Pistol Polishing Station with dispensing gun and valve

Specifications are the same as for 90006-01 except for the following changes.

Agency Approval. Station conforms to European Community electrical safety and EMC directives and has CE conformity markings.

Electrical Requirements. 230 volts, 50 Hz, 4 amps AC.

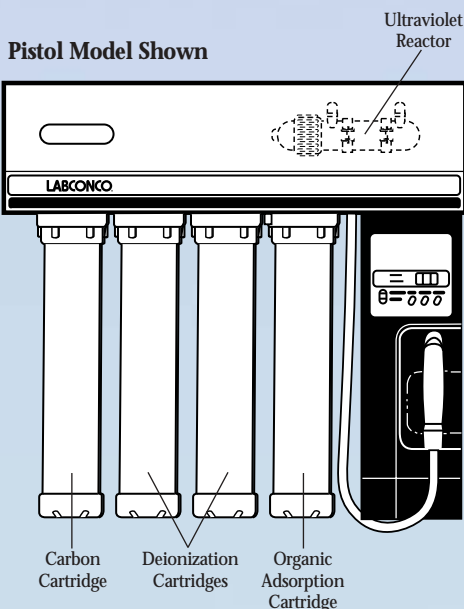

Purification Technologies/Features:

Carbon Filtration

An activated carbon filter removes organics and chlorine from the feedwater.

Deionization

Two polishing grade mixed bed deionization cartridges remove inorganic impurities.

Organic Adsorption

An organic adsorption cartridge removes trace organics.

Ultraviolet Reactor

UV light with dual wavelengths of 185 and 254 nm ensures low TOC and bacteria levels.

TOC Dump Valve

Directs a small portion of purified water to drain during intermittent recirculation, to maintain low TOC values.

Continuous/Intermittent Recirculation

Maintains water quality and inhibits bacteria growth throughout the system.

Optional Hollow Fiber Final Filter 90929-00

Removes bacteria at the dispensing valve or gun. Ordered separately.

* International electrical configuration



Water Produced: Type I (up to 18.2 megohm-cm), pyrogen-free to 0.06 eu/ml

TOC: <10 ppb

Typical Dispensing Rate: 1.1 liters/minute

Typical Dispensing Rate with optional Hollow Fiber Final Filter: 1.0 liter/minute

Applications: cell culture, clinical and life science

Technologies Used: carbon filtration, deionization, ultrafiltration, ultraviolet exposure

Required Polishing Kit: 90471-01 (one carbon and three deionization cartridges)

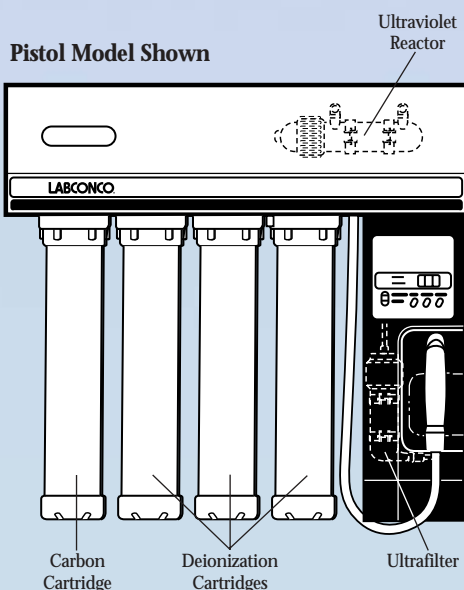

Purification Technologies/Features:

Carbon Filtration

An activated carbon filter removes organics and chlorine from the feedwater.

Deionization

Three polishing grade mixed bed deionization cartridges remove inorganic impurities.

Ultrafiltration

An ultrafilter removes all particles, microorganisms and pyrogens greater than 0.01 micron in diameter (10,000 Dalton cut-off).

Ultrafilter Flush Valve

Directs a small portion of purified water to drain during intermittent recirculation, to maintain ultrafilter efficiency.

Ultraviolet Reactor

UV light with dual wavelengths of 185 and 254 nm ensures low TOC and bacteria levels.

Continuous/Intermittent Recirculation

Maintains water quality and inhibits bacteria growth throughout the system.

Optional Hollow Fiber Final Filter 90929-00

Removes bacteria at the dispensing valve or gun. Ordered separately.

Specifications

90007-00 WaterPro PS/UF Polishing Station

Bowls. 20 1/4" h (51.4 cm). Four bowls constructed of unpigmented virgin natural polypropylene for one carbon and three deionization cartridges. A spanner wrench is provided for filter changes. **Cartridges are not included. Refer to Polishing Kit 90471-01, page 21.**

Cabinet. 31 1/8" w x 7 23/32" d x 8 5/8" h (79.1 x 19.6 x 21.9 cm). Overall height including bowls: 28 7/8" (73.3 cm). Constructed of epoxy-coated steel with Type 304 stainless steel front panel. Includes 1/4 hp motor/rotary vane recirculation pump and water pressure regulator.

Continuous/Intermittent Recirculation. In the ON setting, the system continuously recirculates through the polishing loop. In the OFF setting, the system automatically starts and circulates water through the polishing loop for approximately 4 minutes every 2 hours to minimize rinse up time and bacteria growth.

Control Panel. Includes ON/OFF switch; LED display; MEG Ω , TEMP. $^{\circ}$ C, TIME DISP. and SET PT. indicator lights; DISPENSE switch for water delivery control from valve; MODE switch for selecting LED display; and increase/decrease switch for setting time from 0 to 99.9 minutes or set point from 0 to 16 megohm-cm. Depending on mode selected, LED display shows actual water quality in megohm-cm, actual water temperature in $^{\circ}$ C, dispense time in minutes, or water quality set point in megohm-cm, and flashes when quality drops below set point.

Dispensing Center. Constructed of pressure-formed thermoplastic.

Dispensing Valve. Located on the dispensing center, valve typically delivers 1.1 liters/minute of Type I, pyrogen-free water by pressing the DISPENSE switch or activating TIME DISP. Typical dispensing rate with optional Hollow Fiber Final Filter (not included) is 1.0 liter/minute. If TIME DISP. is activated, water dispensing from the valve automatically shuts off once user-set time has elapsed.

Electrical Requirements. 115 volts, 60 Hz, 7.5 amps AC. Unit includes an 8-foot, 3-wire cord and plug.

Plumbing Connections. Feedwater line should be 3/8" OD rigid plastic tubing or 3/8" ID flexible tubing. Drain port connection to 3/8" OD line is provided.

Ultrafilter and Flush Valve. One ultrafilter is included. Valve operates during intermittent recirculation to maintain ultrafilter efficiency.

Ultraviolet Reactor. Lamp with dual wavelengths of 185 and 254 nm eliminates trace organics and bacteria.

Shipping weight 60 lbs. (27.2 kg)

90007-01 WaterPro PS Pistol Polishing Station with dispensing gun and valve

Specifications are the same as for 90007-00 except for the following changes.

Dispensing Gun. Rests in the dispensing center and is attached to a 3-foot (7.6 cm) flexible recirculating line. The hand-held gun typically delivers 1.1 liters/minute of Type I, pyrogen-free by depressing the trigger. Typical dispensing rate with optional Hollow Fiber Final Filter (not included) is 1.0 liter/minute.

Dispensing Valve. Located on the polishing station.

*90007-02 WaterPro PS Polishing Station with dispensing valve

Specifications are the same as for 90007-00 except for the following changes.

Agency Approval. Station conforms to European Community electrical safety and EMC directives and has CE conformity markings.

Electrical Requirements. 230 volts, 50 Hz, 4 amps AC.

*90007-03 WaterPro PS Pistol Polishing Station with dispensing gun and valve

Specifications are the same as for 90007-01 except for the following changes.

Agency Approval. Station conforms to European Community electrical safety and EMC directives and has CE conformity markings.

Electrical Requirements. 230 volts, 50 Hz, 4 amps AC.

* International electrical configuration

Water Produced: Type I (up to 18.2 megohm-cm) from valve, Type I pyrogen-free to 0.06 eu/ml from gun

TOC: <5 ppb (from valve)

Typical Dispensing Rate: 1.8 liters/minute through valve, 1.1 liters/minute through gun

Typical Dispensing Rate with optional Hollow Fiber Final Filter: 1.1 liter/minute through valve, 1.0 liter/minute through gun

Applications: HPLC and other instrument analyses, life science applications

Technologies Used: carbon filtration, deionization, organic adsorption, ultrafiltration, ultraviolet exposure

Required Polishing Kit: 90472-01 (one carbon, two deionization and one organic adsorption cartridges)

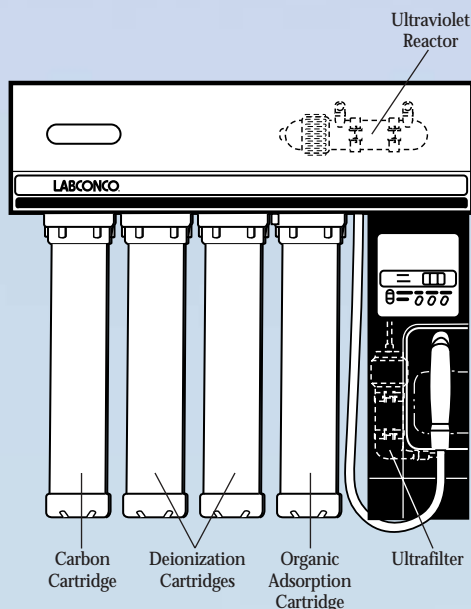

Purification Technologies/Features:

Carbon Filtration

An activated carbon filter removes organics and chlorine from the feedwater.

Deionization

Two polishing grade mixed bed deionization cartridges remove inorganic impurities.

Organic Adsorption

An organic adsorption cartridge removes trace organics.

Ultrafiltration

An ultrafilter removes all particles, microorganisms and pyrogens greater than 0.01 micron in diameter (10,000 Dalton cut-off).

Ultrafilter Flush/TOC Dump Valve

Flushes the ultrafilter membrane and directs a small portion of purified water to drain during intermittent recirculation, to maintain ultrafilter efficiency and low TOC values.

Ultraviolet Reactor

UV light with dual wavelengths of 185 and 254 nm ensures low TOC and bacteria levels.

Continuous/Intermittent Recirculation

Maintains water quality and inhibits bacteria growth throughout the system.

Optional Hollow Fiber Final Filter 90929-00

Removes bacteria at the dispensing valve or gun. Ordered separately.

Specifications

90007-04 WaterPro PS HPLC/UF Hybrid Polishing Station with dispensing gun and valve

Bowls. 20 1/4" h (51.4 cm). Four bowls constructed of unpigmented virgin natural polypropylene for one carbon, two deionization and one organic adsorption cartridges. A spanner wrench is provided for filter changes.

Cartridges are not included. Refer to Polishing Kit 90472-01, page 21.

Cabinet. 31 1/8" w x 7 23/32" d x 8 5/8" h (79.1 x 19.6 x 21.9 cm). Overall height including bowls: 28 7/8" (73.3 cm). Constructed of epoxy-coated steel with Type 304 stainless steel front panel. Includes 1/4 hp motor/rotary vane recirculation pump and water pressure regulator.

Continuous/Intermittent Recirculation. In the ON setting, the system continuously recirculates through the polishing loop. In the OFF setting, the system automatically starts and circulates water through the polishing loop for approximately 4 minutes every 2 hours to minimize rinse up time and bacteria growth.

Control Panel. Includes ON/OFF switch; LED display; MEG Ω , TEMP. $^{\circ}$ C, TIME DISP. and SET PT. indicator lights; DISPENSE switch for water delivery control from valve; MODE switch for selecting LED display; and increase/decrease switch for setting time from 0 to 99.9 minutes or set point from 0 to 16 megohm-cm. Depending on mode selected, LED display shows actual water quality in megohm-cm, actual water temperature in $^{\circ}$ C, dispense time in minutes, or water quality set point in megohm-cm, and flashes when quality drops below set point.

Dispensing Center. Constructed of pressure-formed thermoplastic.

Dispensing Gun. Rests in dispensing center and is attached to a 3-foot (7.6 cm) flexible recirculating line. The hand-held gun typically delivers 1.1 liters/minute of Type I, pyrogen-free water by depressing the trigger. Typical dispensing rate with optional Hollow Fiber Final Filter (not included) is 1.0 liter/minute.

Dispensing Valve. Located on the polishing station, valve typically delivers 1.8 liters/minute of Type I by pressing the DISPENSE switch or activating TIME DISP. Typical dispensing rate with optional Hollow Fiber Final Filter (not included) is 1.1 liters/minute. If TIME DISP. is activated, water dispensing from the valve automatically shuts off once user-set time has elapsed.

Electrical Requirements. 115 volts, 60 Hz, 7.5 amps AC. Unit includes an 8-foot, 3-wire cord and plug.

Plumbing Connections. Feedwater line should be 3/8" OD rigid plastic tubing or 3/8" ID flexible tubing. Drain port connection to 3/8" OD line is provided.

Ultrafilter and Ultrafilter Flush/TOC Dump Valve. One ultrafilter is included. Valve operates during intermittent recirculation to maintain a low TOC level <5 ppb and ultrafilter efficiency.

Ultraviolet Reactor. Lamp with dual wavelengths of 185 and 254 nm eliminates trace organics and bacteria.

Shipping weight 60 lbs. (27.2 kg)

*90007-05 WaterPro PS HPLC/UF Hybrid Polishing Station with dispensing gun and valve

Specifications are the same as for 90007-04 except for the following changes.

Agency Approval. Station conforms to European Community electrical safety and EMC directives and has CE conformity markings.

Electrical Requirements. 230 volts, 50 Hz, 4 amps AC.

* International electrical configuration



Rigorous testing has been conducted on WaterPro PS Polishing Stations to ensure that high purity water is delivered. The charts and technical specifications given below, which represent actual test results, show that water produced by the WaterPro PS meets or exceeds standards set by the ASTM and NCCLS.

Technical Specifications – Type I Water

Bacteria	
General Chemistry and Analytical Instrument models	<1 cfu/ml (with optional Hollow Fiber Final Filter installed)
Life Science and Hybrid models	<1 cfu/100 ml
Silicate	Not detectable
Specific Resistance	Up to 18.2 megohm-cm at 25° C
Particulate Matter	None
TOC (General Chemistry and Life Science Models 90005-00, 90005-01, 90005-02, 90005-03, 90007-00, 90007-01, 90007-02, and 90007-03)	<10 ppb
TOC (Analytical Instrument and Hybrid Models 90006-00, 90006-01, 90006-02, 90006-03, 90007-04, and 90007-05)	<5 ppb
Pyrogens (Life Science and Hybrid Models 90007-00, 90007-01, 90007-02, 90007-03 and 90007-04 and 90007-05 from gun)	Pyrogen-free to 0.06 eu/ml Typical 3x log reduction
Water Standards	Meets or exceeds ASTM and NCCLS Type I specifications

Typical Dispensing Rates*

General Chemistry and Analytical Instrument models	1.8 liters/minute 1.2 liters/minute (with optional Hollow Fiber Final Filter installed)
Life Science models	1.1 liters/minute 1.0 liter/minute (with optional Hollow Fiber Final Filter installed)
Hybrid models	1.8 liters/minute through valve 1.1 liters/minute through valve (with optional Hollow Fiber Final Filter installed) 1.1 liters/minute through gun 1.0 liter/minute through gun (with optional Hollow Fiber Final Filter installed)

Feedwater Requirements

Water Purity	100 µs conductivity or better
Minimum Pressure	0 psi
Maximum Pressure	100 psi
Temperature	4-30° C (40-83° F)
pH	5-9

*depending on feedwater flow rate and pressure

ICP/MS Analysis

(Models 90005-00, 90005-01, 90005-02, 90005-03, 90006-00, 90006-01, 90006-02, 90006-03, 90007-04*, 90007-05*)

Element	ppb	Element	ppb
Al	<0.07	Mo	<0.02
Sb	<0.02	Nd	<0.02
As	<0.2	Ni	0.06
Ba	<0.01	Nb	<0.02
Be	<0.04	Os	<0.02
Bi	<0.04	Pb	<0.06
B	<0.5	Pt	<0.08
Cd	<0.03	Pr	<0.01
Ca	<5	Re	<0.06
Ce	<0.01	Ph	<0.02
Cs	<0.02	Rb	<0.01
Cr	0.08	Ru	<0.05
Co	<0.01	Sm	<0.04
Cu	0.1	Sc	<0.05
Dy	<0.04	Se	<7
Er	<0.02	Ag	<0.03
Eu	<0.02	Na	0.11
Gd	<0.04	Sr	<0.01
Ga	<0.04	Ta	<0.02
Ge	<0.05	Te	<0.04
Au	<0.05	Tb	<0.02
Hf	<0.03	Tl	<0.05
Ho	<0.01	Th	<0.02
In	<0.02	Tm	<0.01
Ir	<0.06	Sn	<0.02
Fe	<0.2	Ti	<0.05
La	<0.01	W	<0.01
Pb	<0.05	U	<0.02
Li	<0.03	V	<0.03
Lu	<0.01	Yb	<0.03
Mg	<0.02	Y	<0.02
Mn	0.05	Zn	<0.05
Hg	<0.05	Zr	<0.01

Ion Chromatography

(Models 90005-00, 90005-01, 90005-02, 90005-03, 90006-00, 90006-01, 90006-02, 90006-03, 90007-04*, 90007-05*)

Cations	ppb	Anions	ppb
Li	ND	F	0.033
Na	ND	Cl	0.85
NH ₄	0.025	NO ₂	<0.05
K	ND	HPO ₄	ND
		Br	ND
		NO ₃	<0.025
		SO ₄	0.046
		CH ₃ CO ₂	0.073
		CH ₃ SO ₃	ND
		HCO ₂	0.096
		C ₂ O ₄	<0.025

ND = not detectable
* from dispensing valve



Expendables

90471-01 General Chemistry/UF Polishing Kit.

(Required for Models 90005-00, 90005-01, 90005-02, 90005-03, 90007-00, 90007-01, 90007-02 and 90007-03). Includes Activated Carbon Cartridge (1), polishing grade mixed bed Deionization Cartridges (3). Shipping weight 9.5 lbs. (4.3 kg)

90472-01 HPLC/Hybrid Polishing Kit.

(Required for Models 90006-00, 90006-01, 90006-02, 90006-03, 90007-04 and 90007-05). Includes Activated Carbon Cartridge (1), polishing grade mixed bed Deionization Cartridges (2), and Organic Adsorption Cartridge (1). Shipping weight 9.5 lbs. (4.3 kg)

90072-01 Activated Carbon Cartridge.

Shipping weight 4 lbs. (1.8 kg)

90073-01 Deionization Cartridge,

polishing grade mixed bed. Shipping weight 4 lbs. (1.8 kg)

90533-00 Organic Adsorption Cartridge.

Shipping weight 4 lbs. (1.8 kg)

91044-00 Replacement Ultrafilter,

spiral-wound, polysulfone membrane. Shipping weight 3 lbs. (1.4 kg)

91092-00 Replacement UV Lamp,

185 and 254 nanometers. Labconco recommends annual UV lamp replacement. Shipping weight 0.5 lb. (0.2 kg)

90929-00 Hollow Fiber Final Filter, self-venting.

Optional filter attaches to the dispensing valve or gun. Removes all particulates and bacteria that are larger than 0.2 micron in diameter. Shipping weight 0.5 lb. (0.2 kg)

90441-00 Filling Bell.

Optional plastic bell attaches to dispensing valve to guard against airborne contaminants. May be used with or without optional

Hollow Fiber Final Filter 90929-00 (sold separately). Shipping weight 0.5 lb. (0.2 kg)



Accessories

91132-00 **WaterPro RO/PS Mobile Stand** Adds portability to your WaterPro RO Station and WaterPro PS Polishing Station.

Constructed of glacier white epoxy-coated steel with 2" diameter hard rubber casters.

Includes hardware to mount the WaterPro RO and WaterPro PS back-to-back on the stand. If desired, a single WaterPro PS may be mounted on one side or two WaterPro PS stations may be mounted back-to-back.

Dimensions (with WaterPro RO Station and WaterPro PS Station attached): 31 1/8" w x 23 1/2" d x 43 1/2" h (79.1 x 59.1 x 110.5 cm). Shipping weight 40 lbs. (18.1 kg)



90774-00 Support Stand.

Optional stand rests on countertop or other horizontal surface when benchtop mounting is preferred. Constructed of glacier white epoxy-coated steel.

Dimensions (with WaterPro PS Polishing Station attached): 31 1/8" w x 16 1/8" d x 35 1/3" h (79 x 41 x 90 cm).

Shipping weight 20 lbs. (9.1 kg)



91093-00 Analytical Instrument Model Conversion Kit.

Includes the UV Lamp, TOC Flush Valve and hardware necessary to convert a WaterPro PS General Chemistry model to a WaterPro PS/HPLC Analytical Instrument model. Shipping weight 1.5 lbs. (0.7 kg)

91094-00 Life Science Model Conversion Kit.

Includes the Ultrafilter, UV Lamp, Ultrafilter Flush Valve and hardware necessary to convert a WaterPro PS General Chemistry model to a WaterPro PS/UF Life Science model. Shipping weight 2.6 lbs. (1.2 kg)



Dimensional Data

WaterPro PS Polishing Station with Dispensing Valve

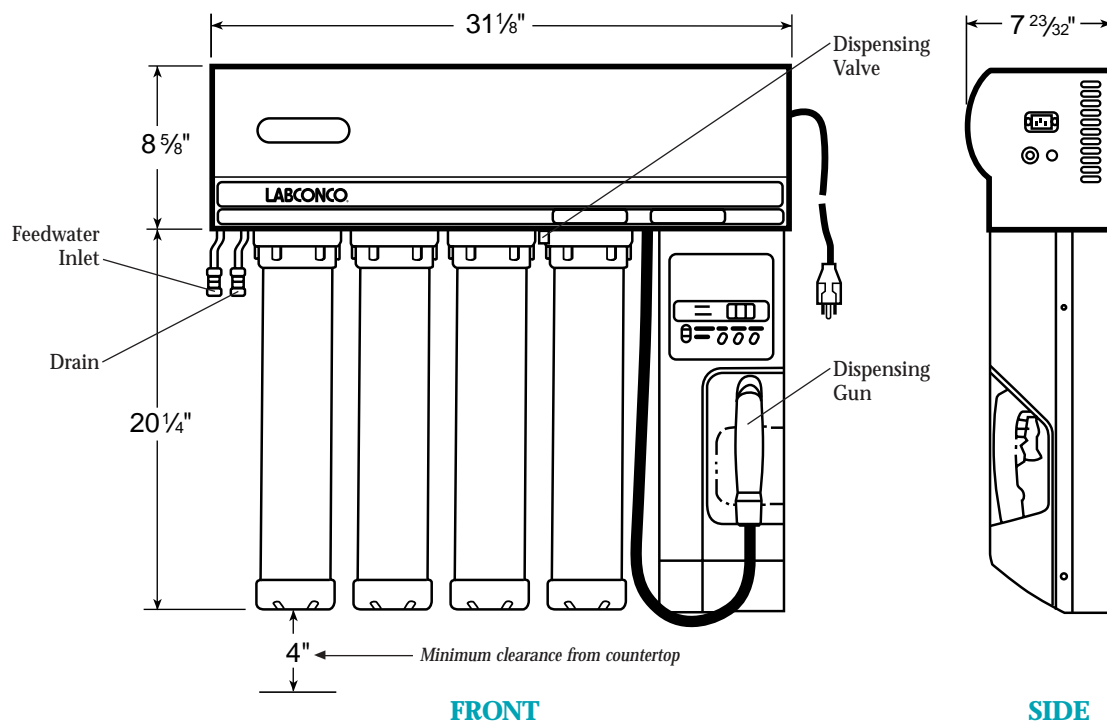
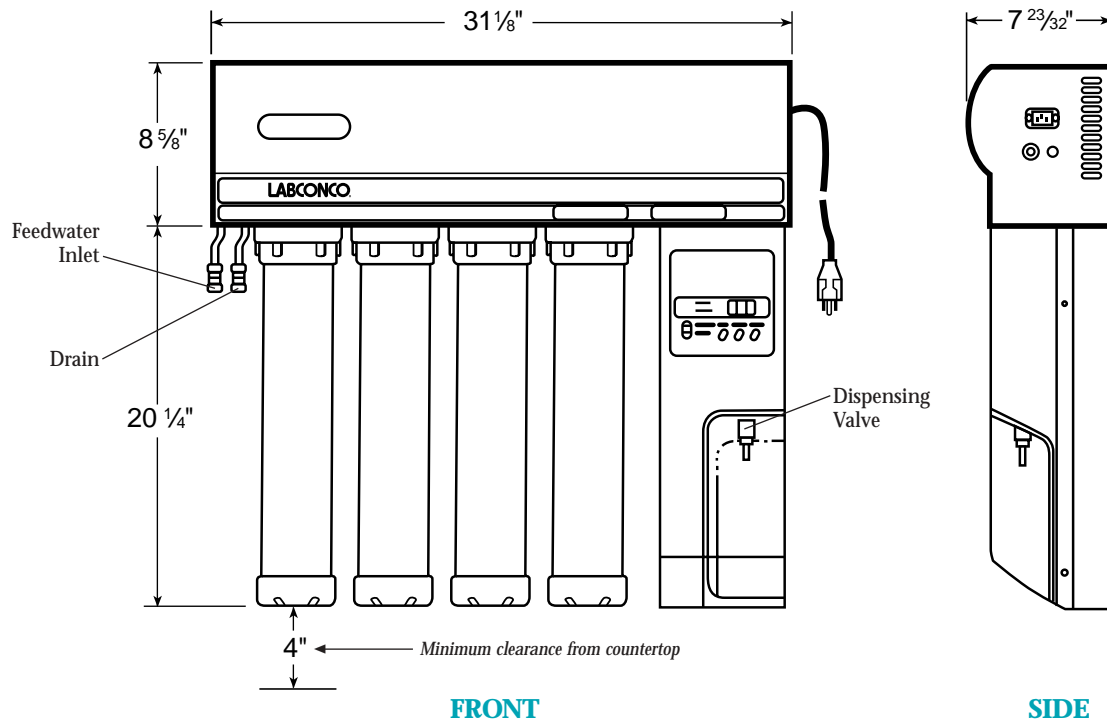



WaterPro PS Polishing Station 90005-00, WaterPro RO Station 90750-00 and WaterPro Softener 90733-00

Plumbing Diagram

This diagram illustrates the connections of WaterPro Water Purification System components.

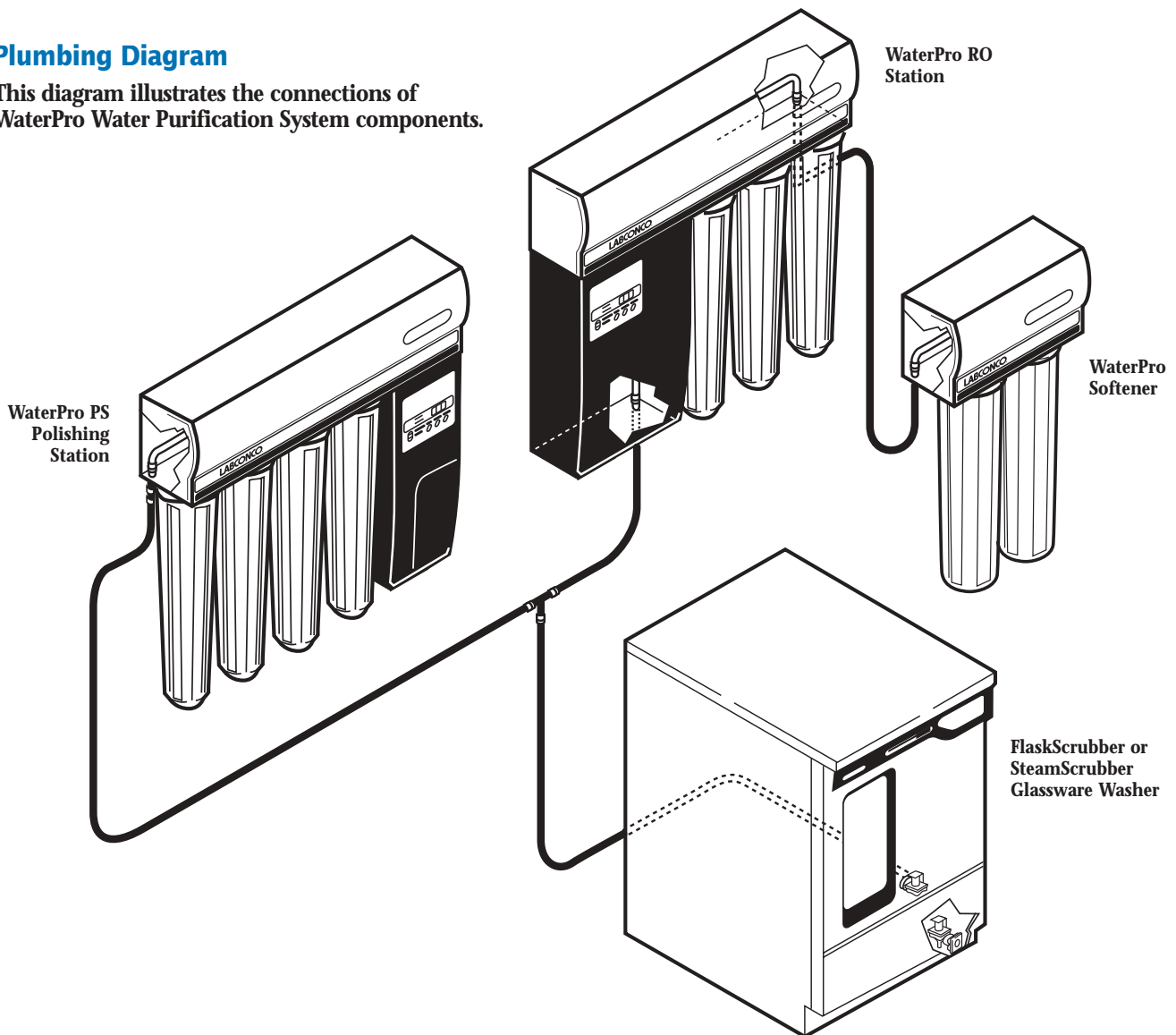



Activated Carbon: A porous carbon material used for adsorption of organics and absorption of free chlorine.

Adsorption: The physical attraction and adherence of gas or liquid molecules to the surface of a solid.

Anion: A negatively charged particle or ion.

BOD: Biological oxygen demand.

Carbon fines: Very small particles of carbon that may wash out of an activated carbon filter.

Cartridge: A prepacked method for housing the filtering components of a water purification system. Because of the modular design of filter elements placed in a cartridge, the changing of exhausted filters is greatly facilitated.

Cation: A positively charged particle or ion.

Cfu/ml: Colony forming units per milliliter; a measure of viable microbial populations in water.

COD: Chemical oxygen demand.

Colloid: A stable dispersion of molecular aggregates in water that have a size ranging between one and two hundred millimicrons. Colloidal iron, aluminum, and silica are commonly found in water.

Concentrate: The reject water from a reverse osmosis membrane; called the concentrate because it contains a higher level of contaminants than the feedwater.

Conversion rate: A quantification of the relationship between the volume of feed and product water of a reverse osmosis membrane.

Dalton: A unit of molecular weight, 1.66×10^{-24} grams: One Dalton is equivalent to the weight of one hydrogen atom. 1,000 Daltons are equivalent to a .0013 micron diameter for globular proteins.

Deionization: The process of removing the charged constituents or ionizable salts (both organic and inorganic) from solution. A purification process that uses synthetic resins to accomplish the selective exchange of hydrogen or hydroxyl ions for the ionized impurities in the water.

Distillation: A purification process involving the phase change of water from liquid to vapor and back to liquid, leaving behind certain impurities.

Electrodialysis: A purification process that removes impurities from water using an electrical current to draw ionic contaminants through ion selective membranes (ion exchange resin in sheet form) and away from the purified water.

Endotoxin: The lipopolysaccharide fragments of bacterial cell walls, ranging in size from 15,000 to one million Daltons in size; considered pyrogenic if they have a fever inducing effect.

Endotoxin Units: EU; a quantification of endotoxin levels using the LAL test.

Exhaustion: The state in which an ion exchange resin is no longer capable of useful absorption: the depletion of the exchanger's supply of available ions. The exhaustion point is typically determined in terms of the reduction in quality of the effluent water as determined by a conductivity bridge which measures the resistance of the water to the flow of an electric current.

Exotoxin: A toxic substance secreted by a bacterium, often causing disease, such as tetanus or botulism.

Feedwater: The water brought to a filtering method before it is filtered; the water entering a purification system.

GC: Gas chromatography.

Grain: A unit of weight; 0.0648 gram, 0.000143 pound.

Hardness: The scale-forming and lather-inhibiting qualities which water possesses when it has high concentrations of calcium and magnesium ions. Temporary hardness, caused by the presence of magnesium or calcium bicarbonate, is so-called because it may be removed by boiling the water to convert the bicarbonates to the insoluble carbonates. Calcium sulfate, magnesium sulfate, and the chlorides of these two elements cause permanent hardness.

Hardness as calcium carbonate: The expression ascribed to the value obtained when the hardness-forming salts are calculated in terms of equivalent quantities of calcium carbonate; a convenient method of reducing all salts to a common basis for comparison.

HPLC: High performance liquid chromatography; an analytical technique for separating one organic compound from another based on differential molecule weights and polarities.

Hydroxyl: The term used to describe the anion (OH⁻) which is responsible for the alkalinity of a solution.

ICP: Inductively coupled plasma; a technique for analyzing a large number of different heavy metals simultaneously, usually preceded by a digestion using concentrated strong acids.

Ion: Any nonaggregated particle of less than colloidal size possessing either a positive or a negative electric charge.

Kilohms: One thousand ohms.

LAL: Limulus Amoebocyte Lysate, a test for pyrogen/endotoxin levels. LAL is an extract from the horseshoe crab which forms a gel in the presence of sufficient pyrogens.

Langelier Saturation Index: The tendency of water to deposit scale. A negative index indicates a tendency to dissolve CaCO₃ and a positive index indicates a tendency to deposit CaCO₃.

Mass Spectroscopy: A very sophisticated technique for molecular analysis that breaks a molecule into recognizable portions.

Megohm: A unit of electrical resistance; one million ohms.

Megohm-cm: The measure of electrical resistance across a one centimeter gap, used as an indicator of ionic contamination.

Micron: 1×10^{-3} millimeters; 1×10^{-6} meters; also known as a micrometer.

Microsiemen: A unit of measure of conductivity; also called micromho; the inverse of the megohm; 1×10^{-6} siemens. One microsiemen is equal to one megohm; ten microsiemens are equal to 0.1 megohm.

Monovalent: An ion in solution that has given up or gained only one electron, represented by one plus or minus sign in front of the ion's symbol. Sodium ion (Na⁺), chloride ion (Cl⁻), and ammonium ion (NH₄⁺) are all monovalent ions.

Mixed Bed Ion Exchange: A combination of anionic and cationic exchange resins mixed together in one container.

Nanograms: 1×10^{-9} grams; 0.000000001 gram.

NCCLS: The National Committee for Clinical Laboratory Standards.

Organic Adsorption: A purification method which picks up trace amounts of organic contaminants to achieve low TOC levels.

pH: An expression of the acidity of a solution; the negative logarithm of the hydrogen ion concentration. pH 1 is very acidic; pH 7 is neutral, the theoretical pH of water; and pH 14 is very basic. The electromotive force between a glass electrode and a reference electrode when immersed in an aqueous solution as compared to that measured for a reference buffer solution.

Polish: The process of removing the remaining contaminants from a preprocessed feedwater.

Polishing Grade Mixed Bed Deionizing Resin: High quality grade of resin for ultimate performance.

Pyrogen: A thermostable component of gram-negative bacteria cell walls that may cause a fever when injected or infused.

Reject Water: The water from a reverse osmosis membrane which contains a higher level of contaminants than the feedwater that is carried out the drain; the concentrate.

Reverse Osmosis: A process in which water is forced under a pressure sufficient to overcome osmotic pressure through a semipermeable membrane leaving behind a percentage of dissolved organic, dissolved ionic, and suspended impurities, typically 90-100%. Product water quality depends on feedwater quality.

Silt Density Index: SDI; also called the Fouling Index; a test used to determine the concentration of colloids in water; derived from the rate of plugging of a 0.45 micron filter run at 30 psi pressure.

Specific Resistance or Resistivity: The electrical resistance in ohms measured between opposite faces of a one centimeter cube of an aqueous solution at a specified temperature. Resistivity is usually corrected to 25°C and expressed as megohms-cm.

Total Organic Carbon: TOC; measures the degree of contamination by microorganisms and organic compounds.

Total Dissolved Solids: TDS; a semi-quantitative measure of the sum total of organic and inorganic solutes in water.

Turbidity: Refers to the degree of cloudiness of the water caused by the presence of suspended particulate or colloidal material. In a photometric method, turbidity acts as an analyte by reducing the transmission of light; measured in turbidity units.

Ultrafiltration: A process in which water flows tangentially across a semipermeable membrane having a highly asymmetric pore structure. The membrane is tight enough to retain contaminants and macromolecules at its surface while allowing water to pass through. Typical pore diameter may range from 0.1 to 0.002 micron.

Ultraviolet (Photochemical) Oxidation: A process using extremely short wavelength light than can kill microorganisms (disinfection) or cleave organic molecules (photo oxidation) rendering them polarized or ionized and thus more easily filtered from the water.



Companion Products



The WaterPro RO Station may be plumbed to the SteamScrubber® or FlaskScrubber® Laboratory Glassware Washer to provide purified water for the final two rinses. Contact Labconco at 800-821-5525 or 816-333-8811 for more information.

Contact Labconco at 1-800-821-5525 or 1-816-333-8811 for more information about these quality products for your laboratory.



Fume Hoods and Blowers



Carbon Filtered Enclosures



Histology/Pathology Work Stations



HEPA Filtered Safety Cabinets, Enclosures and Clean Benches



Glove Boxes



Glassware Washers



Freeze Dry Systems



Centrifugal Concentrators and Cold Traps



Multiple Sample Evaporation systems



Rotary Evaporators



Laboratory Carts and Blood Drawing Chairs



Vacuum Desiccator



Agricultural Chemistry Products



Digital Chloridometer



Labconco Corporation
 8811 Prospect Avenue
 Kansas City, Missouri 64132-2696
 800-821-5525 • 816-333-8811
 FAX 816-363-0130
 E-MAIL labconco@labconco.com
 HOME PAGE www.labconco.com



Product design subject to change without notice.
 © 2001 by Labconco Corporation. Printed in the U.S.A.

2-23-12/01-SUN-10M-R2